

**TECHNICAL MANUAL  
OPERATOR'S AND-ORGANIZATIONAL  
MAINTENANCE MANUAL  
AIR TRAFFIC CONTROL FACILITY  
AN/TSQ-97  
(NSN 5895-00-137-8548)**

**This copy is a reprint which includes current  
pages from Changes 1 and 2.**

---

**HEADQUARTERS, DEPARTMENT OF THE ARMY**

**1 APRIL 1980**

**WARNING**

Storage Battery BB-451/U uses dangerous chemicals which can cause severe burns if personnel fail to observe safety precautions. Report to hospital or first aid station for treatment. Tell doctor you have been contaminated with Potassium Hydroxide (KOH). To prevent Hydrogen gas explosion, remove Storage Battery BB-451/U from transit position and ventilate cabinet interior before activating radios. Do not seal activated batteries in airtight containers such as transit cases for an extended time, as hydrogen out gassing may create an explosive environment.

**WARNING**

Adequate ventilation should be provided while using TRICHLOROTRIFLUOROETHANE. Prolonged breathing of vapor should be avoided. The solvent should not be used near heat or open flame; the products of decomposition are toxic and irritating. Since TRICHLOROTRIFLUOROETHANE dissolves natural oils, prolonged contact with skin should be avoided. When necessary, use gloves which the solvent cannot penetrate. If the solvent is taken internally, consult a physician immediately.

**WARNING**  
**DANGEROUS CHEMICALS ARE USED**  
**IN SILVER-ZINC BATTERIES**

The electrolyte used in silver-zinc batteries (BB-451/U) contains potassium hydroxide (KOH), which is a caustic chemical agent. Serious and deep burns of body tissue will result if the electrolyte comes in contact with the eyes or any part of the body. Use rubber gloves, rubber apron, and protective goggles when handling the electrolyte. If accidental contact with the electrolyte is made, use ONLY clean water and immediately (seconds count) flush contaminated areas. Continue flushing with large quantities of clean water for at least 15 minutes. Seek medical attention without delay.

**WARNING**

Storage Battery BB451/U uses dangerous chemicals which can cause severe burns if personnel fail to observe safety precautions. Report to hospital or first aid station for treatment. Tell doctor you have been contaminated with Potassium Hydroxide (KOH). To prevent Hydrogen gas explosion, remove Storage Battery BB-451/U from transit position and ventilate cabinet interior before activating radios. Do not seal activated batteries in airtight containers such as transit cases for an extended time, as hydrogen out gassing may create an explosive environment

**WARNING**  
**DO NOT MIX SULPHURIC ACID AND KOH**

The electrolyte used in silver-zinc batteries (BB-451/U) reacts violently to the sulfuric acid used in the more common lead-acid types of batteries. DO NOT add sulphuric acid electrolyte to the battery; the mixing of the acid and KOH electrolytes will cause a violent reaction which could result in the splattering of the mixture into the eyes and onto the skin. Every effort must be made to keep silver-zinc batteries as far away as possible from lead-acid batteries. Do not use the same tools and materials such as screwdrivers, wrenches, syringes, hydrometers, and gloves for both types of batteries. Any trace of acid or acid fumes will permanently damage silver-zinc batteries on contact.

**WARNING**

Storage Battery BB-451/U must not be installed in the facility during prolonged transportation or storage.

**WARNING**

Four people are required to carry the equipment to the selected site.

**WARNING**

**DO NOT STORE OR SHIP THE AN/TSQ-97 WITH STORAGE BATTERY B-451/U INSTALLED.**

Change 1 A

**WARNING**

Adequate ventilation should be provided while using TRICHLOROTRIFLUOROETHANE. Prolonged breathing of vapor should be avoided. The solvent should not be used near heat or open flame; the products of decomposition are toxic and irritating. Since TRICHLOROTRIFLUOROETHANE dissolves natural oils, prolonged contact with skin should be avoided. When necessary, use gloves which the solvent cannot penetrate. If the solvent is taken internally, consult a physician Immediately.

**WARNING**

Do not operate the facility during electrical storms.

**Change1 B**

CHANGE }  
NO. 2 }

HEADQUARTERS  
DEPARTMENT OF THE ARMY  
Washington, DC, 17 September 1984

**Operator's and Organizational  
Maintenance Manual  
AIR TRAFFIC CONTROL FACILITY AN/TSQ-97  
(NSN 5895-00-137-8548)**

TM 11-5895-800-12, 1 April 1980, is changed as follows:

1. New or changed material is indicated by a vertical bar in the margin of the page.
2. Added or revised illustrations are indicated by a vertical bar before figure number and title and by a pointing hand on the illustration pages.
3. Remove old pages and insert new pages as indicated below.

<i>Remove Pages.....</i>	<i>Insert Pages</i>
iii and iv .....	iii and iv
1-0 .....	v and 1-0
1-1 and 1-2.....	1-1 and 1-2
.....	1-2A/(1-2B Blank)
.....	1-8A/(1-8B Blank)
1-9and 1-10.....	1-9 and 1-10
1-13 and 1-14.....	1-13 and 1-14
2-3 and 2-4.....	2-3 and 2-4
2-7/(2-8 Blank) .....	2-7 and 2-8
.....	3-14A/(3-14B blank)
3-15 and 3-16.....	3-15and 3-16
3-17 and 3-18.....	3-17 and 3-18
3-23 and 3-24.....	3-23 and 3-24
A-1/(A-2 Blank) .....	A-1/(A-2 Blank)
C-3 through C-10 .....	C-3 through C-12
E-1 and E-2.....	E-1 and E-2
FO-1/(FO-2 Blank) .....	FO-1/(FO-2 Blank)
.....	FO-1/(FO- 1 B Blank)
FO-9/(FO-10 Blank .....	FO-9/(FO-10 Blank)

4. File this change sheet in front of publication for reference purposes.

By Order of the Secretary of the Army:

Official:

JOHN A. WICKHAM JR.  
General, United States Army  
Chief of Staff

ROBERT M. JOYCE  
*Major General, United States Army*  
*The Adjutant General*

DISTRIBUTION:

To be distributed in accordance with DA Form 12-36B requirements for AN/TSQ-97.

CHANGE }  
NO. 1 }

HEADQUARTERS  
DEPARTMENT OF THE ARMY  
WASHINGTON, DC, 16April 1982

**Operator's and Organizational  
Maintenance Manual  
AIR TRAFFIC CONTROL FACILITY AN/TSQ-97  
(NSN 5895-00-137-8548)**

TM 11-5895-800-12, 1 April 1980, is changed as follows:

1. New or changed material is indicated by a vertical bar in the margin of the page.
2. Added or revised illustrations are indicated by a vertical bar before figure number and title and by a pointing hand on the illustration pages.
3. Remove old pages and insert new pages as indicated below.

<i>Remove Pages</i> .....	<i>Insert Pages</i>
Warning (inside front cover.....)	A and B (Front of manual)
i and ii.....	i and ii
v and 1-0.....	1-0
1-1 through 1-4.....	1-1 through 1-4
1-7 and 1-8.....	1-7 and 1-8
2-1 through 2-7.....	2-1 through 2-7/(2-8 Blank)
3-1 and 3-2.....	3-1 and 3-2
3-7 and 3-8.....	3-7 and 3-8
3-15 through 3-20.....	3-15 through 3-20
3-23, 3-24 and 3-25.....	3-23, 3-24 and 3-251(3-26 Blank)
4-5 through 4-8.....	4-5 through 4-8
A-i and A-2.....	A-11/(A-2Blank)
B-1 and B-2.....	B-1 and B-2
C-3 through C-9.....	C-3 through C-10
D-1 and D-2.....	D-1 and D-2

4. File this change sheet in front of publication for reference purposes.

By Order of the Secretary of the Army:

Official:  
ROBERT M. JOYCE  
*Brigadier General, United States Army*  
*The Adjutant General*

E. C. MEYER  
*General, United States Army*  
*Chief of Staff*

Distribution:

To be distributed in accordance with DA Form 12-36, Organizational Maintenance Requirements for AN/ARC- 14, AN/ARC- 115.



**OPERATOR'S AND ORGANIZATIONAL  
MAINTENANCE MANUAL  
AIR TRAFFIC CONTROL FACILITY AN/TSQ-97  
(NSN 5895-00-137-8548)**

**REPORTING ERRORS AND RECOMMENDING IMPROVEMENTS**

You can help improve this manual. If you find any mistakes or if you know of a way to improve the procedures, please let us know. Mail your letter, DA Form 2028 (Recommended Changes to Publications and Blank Forms), or DA Form 2028-2 located in back of this manual direct to Commander, US Army Communications-Electronics Command, ATTN: DRSEL-ME-MQ, Fort Monmouth, NJ 07703. A reply will be furnished direct to you.

**TABLE OF CONTENTS**

	<u>Paragraph</u>	<u>Page</u>
CHAPTER 1. INTRODUCTION		
SECTION I. General		
Scope .....	1-1	1-1
Index of Technical Publications .....	1-2	1-1
Maintenance Forms, Records, and Reports .....	1-3	1-1
Destruction of Materiel to Prevent Enemy Use .....	1-4	1-1
Administrative Storage.....	1-5	1-1
Hand Receipt Manual.....	1-5.1	1-2
II. Description and Data		
Purpose and Use.....	1-6	1-2
Operating Power .....	1-7	1-2
Physical Description.....	1-8	1-3
Cabling Furnished.....	1-9	1-9
Differences Between Models.....	1-10	1-9
Equipment Supplied.....	1-11	1-12
Associated Equipment Required But Not Supplied .....	1-12	1-13
Tabulated Date .....	1-13	1-13



## TABLE OF CONTENTS -- Continued

	<u>Paragraph</u>	<u>Page</u>
CHAPTER 2. SERVICE UPON RECEIPT AND INSTALLATION		
Section	I. Service Upon Receipt	
	Unpacking.....	2-1 2-1
	Inspection .....	2-2 2-1
	Preparing Storage Battery BB-451/U for Use.....	2-3 2-1
	Tools and Test Equipment Required for Installation.....	2-4 2-1
	Packaging for Limited Storage or Shipment .....	2-5 2-1
	II. Installation Instructions	
	Site Information.....	2-6 2-2
	Equipment Storage During Transit .....	2-7 2-2
	Systems Planning .....	2-8 2-4
	Facility Setup (Installation) .....	2-9 2-4
	Operation From Vehicular Power .....	2-10 2-7
	X-Mode Communications .....	2-11 2-7
CHAPTER 3. OPERATING INSTRUCTIONS		
Section	I. Operator's Controls and Indicators	
	Introduction .....	3-1 3-1
	Damage from Improper Settings .....	3-2 3-1
	Controls and Indicators.....	3-3 3-2
	II. Operation Under Usual Conditions	
	Starting and Checkout Procedures .....	3-4 3-15
	Facility Operation .....	3-5 3-15
	Operating Procedures for Individual Radio Sets .....	3-6 3-18
	Radio Set AN/ARC-114A.....	3-7 3-18
	Radio Set AN/ARC-115(*) .....	3-8 3-19
	Receiver-Transmitter RT-1167/ARC-164(V) .....	3-9 3-21
	Operation of Altimeter in AN/TSQ-97 .....	3-10 3-22
	Density Altitude Computation .....	3-11 3-23
	III. Operation Under Unusual Conditions	
	Recognition and Identification of Jamming .....	3-12 3-23
	Antijamming.....	3-13 3-23
	High Humidity (Rain) Operation.....	3-14 3-23
	IV. Preparation for Movement	
	Battery Cold Weather Limitations .....	3-15 3-24
	Instructions.....	3-16 3-24

TABLE OF CONTENTS -- Continued

	<u>Paragraph</u>	<u>Page</u>
CHAPTER 4. OPERATOR/ORGANIZATIONAL MAINTENANCE INSTRUCTIONS		
Section I.	Introduction	
	General.....	4-1 4-1
	Tools and Equipment Required .....	4-2 4-1
Section II.	Preventive Maintenance Checks and Services (PMCS)	
	PMCS Requirements.....	4-3 4-3
	Cleaning.....	4-4 4-3
	Touchup Painting Instructions .....	4-5 4-4
Section III.	Troubleshooting	
	General Information .....	4-6 4-7
	Remove/Install Parts or Assemblies .....	4-7 4-7
APPENDIX A. REFERENCES .....		
		A-1
APPENDIX B. COMPONENTS OF END ITEM LIST		
Section I.	Introduction .....	B-1
Section II.	Integral Components of the End Item .....	B-2
APPENDIX C. MAINTENANCE ALLOCATION		
Section I.	Introduction .....	C-1
Section II.	Maintenance Allocation Chart for Air Traffic Control Facility AN/TSQ-97 .....	C-4
Section III.	Tool and Test Equipment Requirements for Air Traffic Control Facility AN/TSQ-97 .....	C-8
Section IV.	Remarks .....	C-9
APPENDIX D. EXPENDABLE SUPPLIES AND MATERIALS LIST		
Section I.	Introduction .....	D-1
Section II.	Tabular Listing .....	D-2
APPENDIX E. ADDITIONAL AUTHORIZATION LIST		
Section I.	Introduction .....	E-1
Section II.	Additional Authorization List .....	E-2

LIST OF ILLUSTRATIONS

<u>Figure</u>	<u>Title</u>	<u>Page</u>
1-1	Air Traffic Control Facility AN/TSQ-97 .....	v
1-2	AN/TSQ-97, Assembled for Transportation .....	1-3
1-3	Air Traffic Control Facility, Partial Front View .....	1-5
1-4	AS-1703/ARC-54 with Antenna Coupler CU-942B/ARC-54, Mounted Configuration .....	1-7
1-5	AT-1108/ARC, Antennas, Mounted Configuration .....	1-7
1-6	Wind Direction and Speed Detector ML-653/TSQ-97 .....	1-8
1-7	Cabling Diagram with TSEC/KY-38 Security Equipment .....	1-8A
1-7A	Cabling Diagram with MK-2225/TSQ-97 Installation Kit and TSEC/KY-57 Security Equipment .....	1-9
2-1	Air Traffic Control Facility, Group Assembly OA-8879/TSQ-97, Rear View .....	2-3
2-2	Front Cover Storage Items .....	2-4
2-3	Guy Line and Anchor Pin Positioning .....	2-5
3-1	C-9921/TSQ-97, Front Panel Controls and Indicators .....	3-3
3-2	C-9921/TSQ-97, Rear View .....	3-6
3-3	AN/ARC-114(*) Operator Controls and Indicators .....	3-9
3-4	AN/ARC-11S(*) Operator Controls and Indicators .....	3-9
3-5	RT-1167/ARC-164(V), Operator Controls and Indicators .....	3-12
FO-1	Operational Diagram AN/TSQ-97 with TSEC/KY-38 Security Equipment	FO-1
FO-1A	Operational Diagram AN/TSQ-97 with MK-2225/TSQ-97 Installa- tion Kit and TSEC/KY-57 Security Equipment .....	FO-1A
FO-2	Installation Diagram, Air Traffic Control Facility AN/TSQ-97 .....	FO-3
FO-3	Electrical Schematic Diagrams, AN/TSQ-97 System Cables, MK-2225/TSQ-97 Installation Kit Cables, 50 Foot Power Cable, Radio-Frequency choke MX-9713/TSQ-97, Detector, Wind Direction and Speed ML-9S3/TSQ-97 .....	FO-9

LIST OF TABLES

<u>Table</u>	<u>Title</u>	<u>Page</u>
1-1	Radio/Antenna Configuration .....	1-10
1-2	Items Comprising an Operable Equipment (Items Supplied) .....	1-10
3-1	Controls, Connections and Indicators .....	3-3
3-2	C-9921/TSQ-97, Rear Panel Operator Controls and Indicator .....	3-6
3-3	AN/ARC-114A Front Panel Controls and Indicators .....	3-9
3-4	AN/ARC-115A Front Panel Controls and Indicators .....	3-10
3-5	RT-1167/ARC-164(V) Front Panel Controls .....	3-13
3-6	Preoperation Switch Positions .....	3-16
4-1	Tools/Spares/Equipment Commonly Used .....	4-1
4-2	Organizational Preventive Maintenance Checks and Services .....	4-5
4-3	Troubleshooting Chart .....	4-8

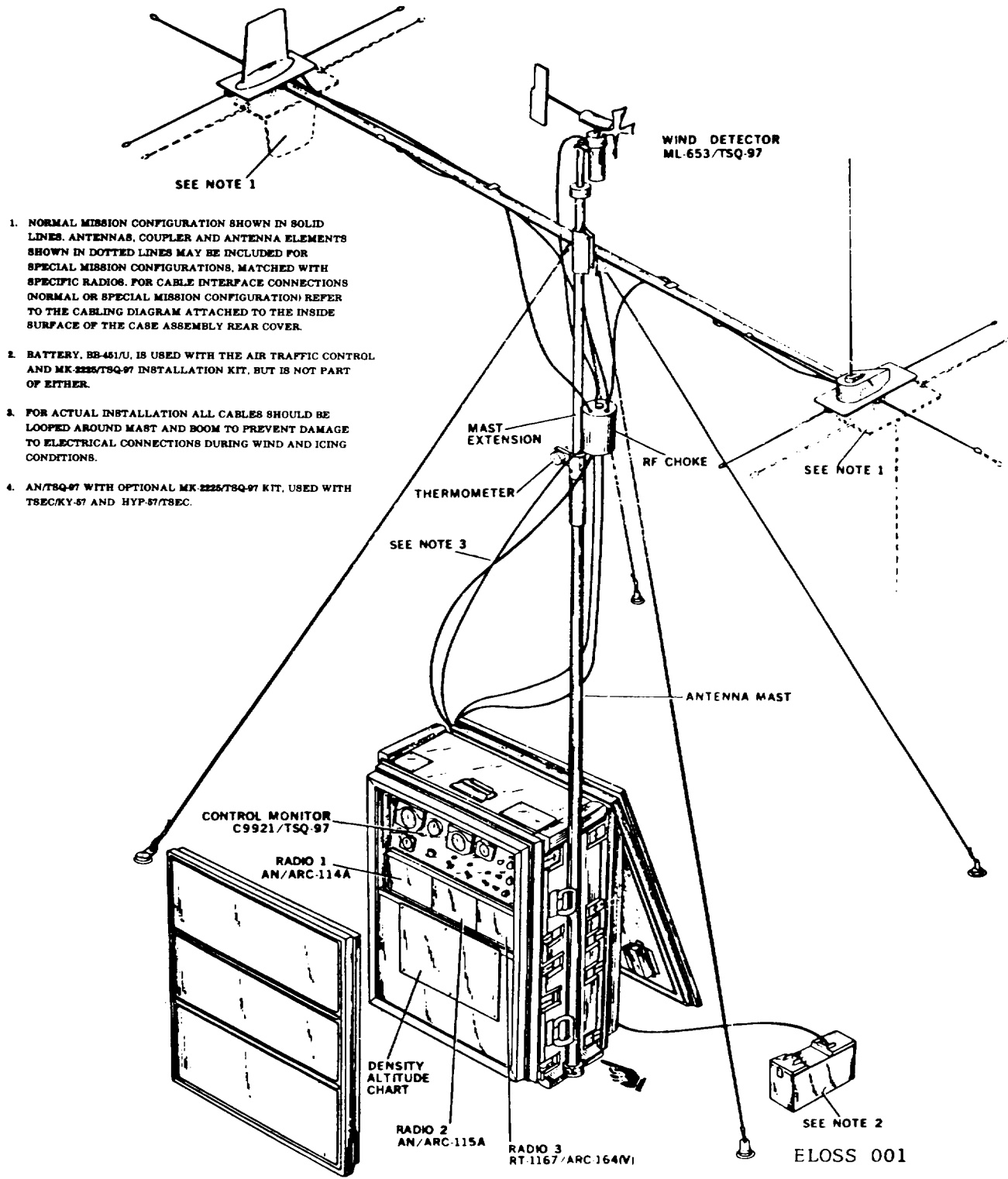


Figure 1-1. Air Traffic Control Facility AN/TSQ-97 (Sheet 1 of 2)  
Change 2 v

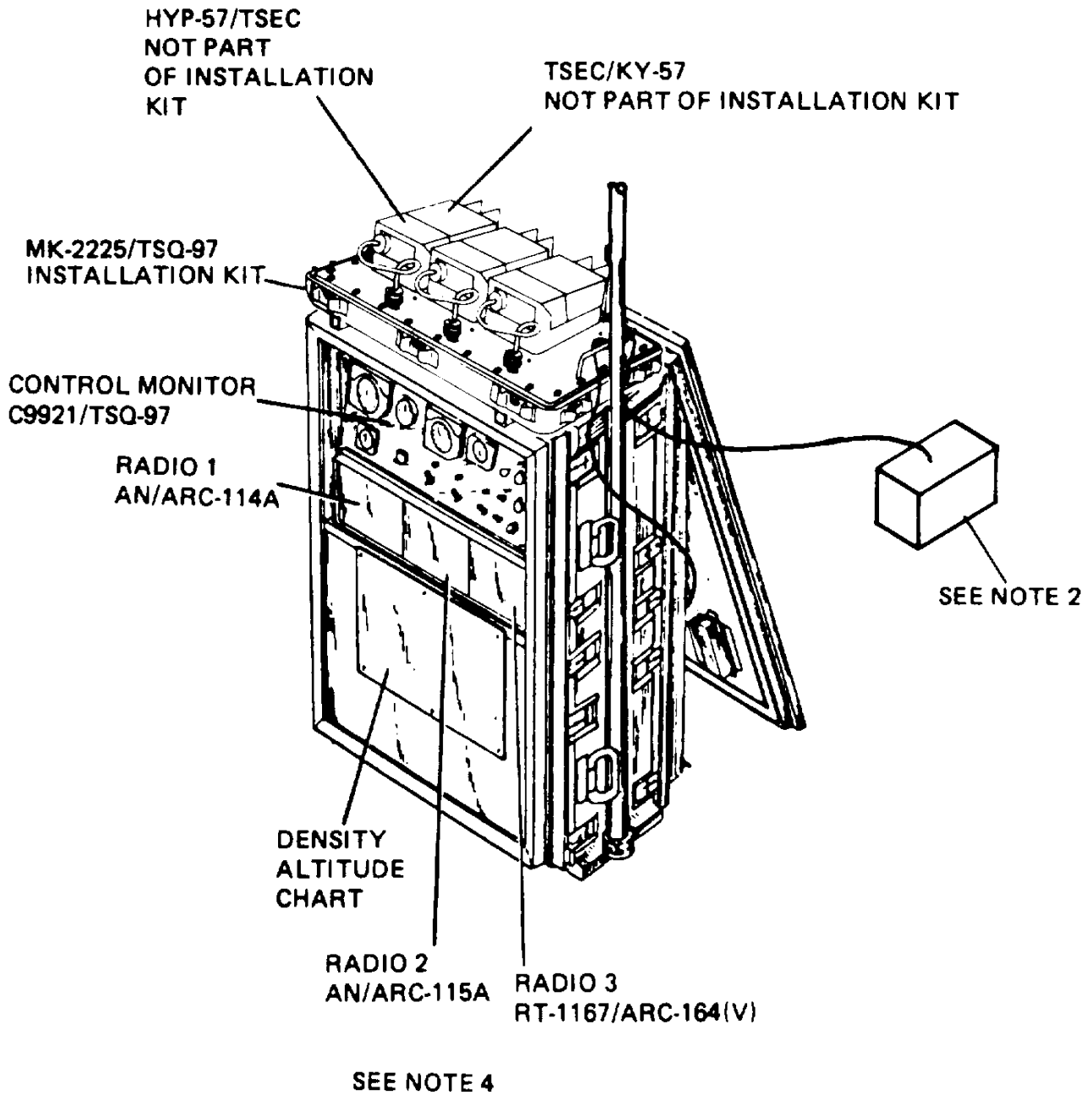


Figure 1-1. Air Traffic Control Facility AN/TSQ-97(Sheet 2)  
Change 2 1-0

## CHAPTER 1 INTRODUCTION

### Section I.

### GENERAL

1-1. Scope. This technical manual provides operation and maintenance instructions applicable to use of the Air Traffic Control Facility AN/TSQ-97 (facility), shown in figure 1-1. Included are operation under both usual and unusual service conditions, cleaning, inspection and replacement of parts authorized for operator and organizational maintenance. The use of Installation Kit MK-2225/ TSQ-97 to interface TSEC/KY-57 secure communications equipment with the AN/TSQ-97 is also discussed in this manual.

1-2. Consolidated Index of Army Publications and Blank Forms. Refer to the latest issue of DA Pam 310-1 to determine whether there are new editions, changes or additional publications pertaining to the equipment.

1-3. Maintenance Forms, Records, and Reports.

a. Reports of Maintenance and Unsatisfactory Equipment. Department of the Army Forms and procedures used for equipment maintenance will be those prescribed by DA Pam 738-750 as contained in Maintenance Management Update.

b. Report of Packaging and Handling Deficiencies. Fill out and forward SF364 (Report of Discrepancy (ROD)) as prescribed in AR 735-11-2/DLAR 4140.55/NAVMATINST 4355.73A/AFR 400-54/MtCO4430.3F.

c. Discrepancy in Shipment Report (DISREP) (SF 361). Fill out and forward Discrepancy in Shipment Report (DISREP) (SF 361) as prescribed in AR 55-38/NAVSUPINST 4610. 33C/AFR 75-18/MCO P4610. 19D/DLAR 4500.15.

d. Reporting Equipment Improvement Recommendations (EIR). If your Air Traffic Control Facility AN/TSQ-97 needs improvement, let us know. Send us an EIR. You, the user, are the only one who can tell us what you don't like about your equipment. Let Put it on an SF 368 (Quality Deficiency Report). Mail it to Commander, US Army Communications-Electronics Command and Fort Monmouth, ATTN: DRSEL-ME-MP, Fort Monmouth, New Jersey 07703-5007. We'll send you a reply.

1-4. Destruction of Army Electronics Materiel. Destruction of Army electronics materiel to prevent enemy use shall be in accordance with TM 750-244-2.

1-5. Administrative Storage.

a. General. Electronic equipment that is placed in administrative storage should be capable of being ready for use within a 24-hour period. Select the best available site for storage. Separate stored equipment from equipment use. Conspicuously mark the area "Administrative Storage".

Change 2 1-1

*b. Maintenance Services.* Before the Air Traffic Control Facility AN/TSQ-97 is placed in administrative storage, perform the operational procedures in Section II of Chapter 3 in this manual. Faulty equipment should not be placed in storage. If equipment fails the operational procedures, troubleshoot using the procedures in Section III of Chapter 4 in this manual. Further, clean the equipment so that it is free of dirt, grease, and other contaminants using the procedures in Chapter 4 of this manual. Remove rust and damaged paint by scraping, wire brushing, sanding or buffing. Sand to a smooth finish and spot paint using the procedures in Section II of Chapter 4 of this manual.

*c. Removal from Storage.* When Air Traffic Control Facility AN/TSQ-97 is

removed from storage, it must be tested to insure that it is operating satisfactorily for use in the field. Test it by using the procedures in Section III of Chapter 3 of this manual.

1-5.1. Hand Receipt Manual. This manual has a companion document with a TM number followed by "-HR" which stands for hand receipt). The TM 11-5895-800-10-HR consists of preprinted hand receipts (DA Form 2062) that list end item related equipment (i.e. COE1, B11, and AAL) you must account for. As an aid to property accountability, additional -HR manuals may be requisitioned from the US Army Adjutant General Publications Center in Baltimore, Maryland in accordance with procedures in Chapter 3, AR 310-2 and DA Pam 310-2.

**Section II. DESCRIPTION AND DATA**

1-6. Purpose and Use. The AN/TSQ 97 is a (four-person) portable Air Traffic Control Facility for control of air traffic at landing zones in forward areas. It can also be used at any landing zone where Visual Flight Rule control is required. Included in the facility are VHF-AM/FM and UHF-AM communications capabilities, meteorological equipment and attendant accessories associated with control of Visual Flight Rule terminal air traffic. Instruments used with the facility indicate wind speed and direction, altitude and real time. The basic facility contains one each Radio Set AN/ARC-114A, AN/ARC-115A, and Receiver-Transmitter RT-1167/ARC-164(V); however, several combinations of these radios may be installed as needed. Cables are supplied to interface security equipment TSEC/KY-38 for &-mode (secure) communications. The facility can also be used with Radio Sets AN/ARC-114(\*), AN/ARC-115(\*), and AN/ARC-116(\*) instead of previously mentioned radios; however, X-mode communications capability does not exist when using the AN/ARC-115(\*) and AN/ARC-116(\*). Installation Kit MK-2225/TSQ-97 is available to allow for use of security equipment TSEC/KY-57 for X-mode (secure) communications. This kit includes the cables and the TSEC/KY-57 mounting base necessary to interface the TSEC/KY-57 security equipment. The TSEC/KY-57 security equipment is used in the vehicular configuration and requires Vehicular Power Adapter HYP-57/TSEC for op-

eration. The TSEC/KY-57 security equipment or ancillary units are not part of the AN/TSQ-97 facility or the MK-2225/TSQ-97 installation kit. Figures FO-1 and FO-1A show the operational diagrams for the facility. Figure FO-2 is the installation drawing for the facility associated.

1-7. Operating Power. There are three sources of power available for the AN/TSQ-97 facility. Storage battery BB-451/U is the usual source of 24 volts dc (normal) operating power. The battery is not supplied with the facility, however, a power cable is provided to connect the BB-451/U to the AN/TSQ-97. Power can also be obtained from a vehicular source using a cable provided with the AN/TSQ-97. An alternate 50 foot power cable CX13202/TSQ-97, not supplied with the AN/TSQ-97, is also available for use with a vehicular power source if remote operations are desired. When operating from a vehicular power source, a transient suppressor (furnished) must be used to damp attendant surges and transients. A third source of power for the AN/TSQ-97 is the MK-2225/TSQ-97 installation Kit. The AN/TSQ-97 is connected to the MK-2225/TSQ-97 PWR OUT connector and the MK-2225/TSQ-97 is connected to battery BB-451/U or a vehicular power source. Separate batteries may be used to power the AN/TSQ-97 and the MK-2225/TSQ-97 installation kit. Storage Battery BB-4S1/U has a capacity

**Change 2 1-2A**



of 25 ampere-hours which will, depending on the communications load, provide up to 8 hours of operation. Battery Terminal Adapter MX-4430(\*)/PRC-47 (furnished) must be installed on top of the battery so that the power cable can be connected. For complete information about BB-451/U refer to TM 11-6140-208-15.

#### NOTE

The AN/TSQ-97 may be operated from any power source providing a DC Voltage between 24 and 30 volts with a current capacity of 10 amperes.

#### 1-8. Physical Description.

*a. General External Description.* Figure 1-2 shows the facility in the ready for transport condition. The entire equipment is contained in a lea proof metal case with removable front and back covers. The case contains a control-monitor panel, three radios (receiver/transmitter) and attendant items required to provide communications and meteorological data. The facility as

shown weighs about 200 pounds and is intended to be personnel-transportable for short distances. The facility less the battery weighs about 185 pounds. Before setup for operation, the metal poles affixed by quick-release pins to the sides of the case serve as carrying handles and provide storage for a mast extension, two whip-type antenna elements, and nylon guy ropes. Stored in the front cover are 6 cable assemblies used when X-mode communications are required, 4 anchor pins to which the guy lines will be attached, and 12 antenna ground plane elements.

*b. Case Description.* The equipment case (interior) is divided into two main compartments. Control-Monitor C-9921/TSQ-97 (control-monitor) is mounted in the upper portion by four shock mounts. The upper compartment is accessible from both front and back. The interior of the lower (storage) compartment is accessible only from the back. Attached to the front panel of the lower compartment is a metal chart for reference to determine density altitude data. Contained in the rear lower compartment is a molded rubber storage area and three

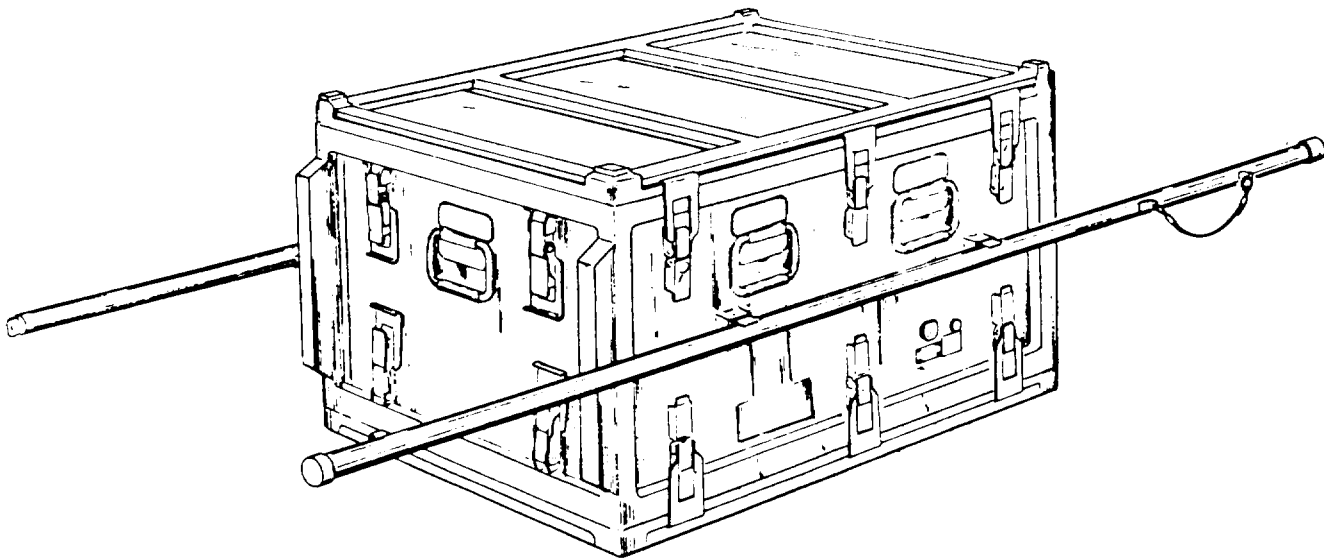


Figure 1-2. AN/TSQ97, Assembled for Transportation

Change 1 1-3

metal storage compartments. The left side compartment contains two input power cables, three antenna to RF choke coaxial cables, three RF choke to radio antenna input coaxial cables, and two cables used with the wind speed and direction sensor. During operation, the center compartment can be used to store the battery that supplies operating power. The right metal compartment stores the microphone and headset/microphone.

- 1 ea. Vane for wind detector
- 1 ea. Standoff (for wind detector)

(1) *Equipment stored in case lower compartment.* The following items are contained in the foam rubber storage area: (Reference figure 2-1)

- 2 ea Antennas AT-1108/ARC mounted
- 1 ea Thermometer
- 1 ea Thermometer bracket
- 2 ea Antenna Couplers CU-942B/ARC-54 mounted
- 1 ea RF Choke MX-9713/TSQ-97
- 1 ea Wind Direction and Speed Detector ML-653/TSQ-97

c. *Interior Description.* Figure 1-3 shows the front cover removed to expose the main operation control panel, Control Monitor C-9921/TSQ-97, the radio set compartment and the density altitude determination chart.

d. *Control Monitor C-9921/TSQ-97.* The C-9921/TSQ-97 (control monitor) consists of an upper compartment and front and rear panels and a lower section where the radios are housed. Mounted on the front panel are the electrical controls and the electrical and meteorological indicators. The function of the controls and indicators is explained in Chapter 3. The front panel compartment containing printed wiring boards and necessary electronics and wiring, is RFI shielded and weathertight. The Standard Lightweight Avionics Equipment radio sets housed behind a plastic shield in the lower compartment are:

Type	Main	Frequency Range		Modulation
			Guard	
RADIO 1 AN/ARC-114A	30.00 - 75.95 MHz		40.00 - 42.00 MHz	FM
RADIO 2 AN/ARC-115sA*	116.000 - 149.975 MHz		119 - 124 MHz	AM
RADIO 3 RT-1167/ ARC-164	225.000 - 399.975 MHz		243 MHz	AM

\*Early equipment's are furnished with AN/ARC-115 which does not have X-mode capability when used with this equipment.

e. *Radio Set AN/ARC-114(\*).* Radio Set AN/ARC-114(\*) is very high frequency (VHF), frequency-modulated (FM), radio receiving-transmitting set that is compatible with aircraft radios and the narrow band AN/VRC-12 series of ground tactical radio sets. The radio set contains a multichannel, electronic

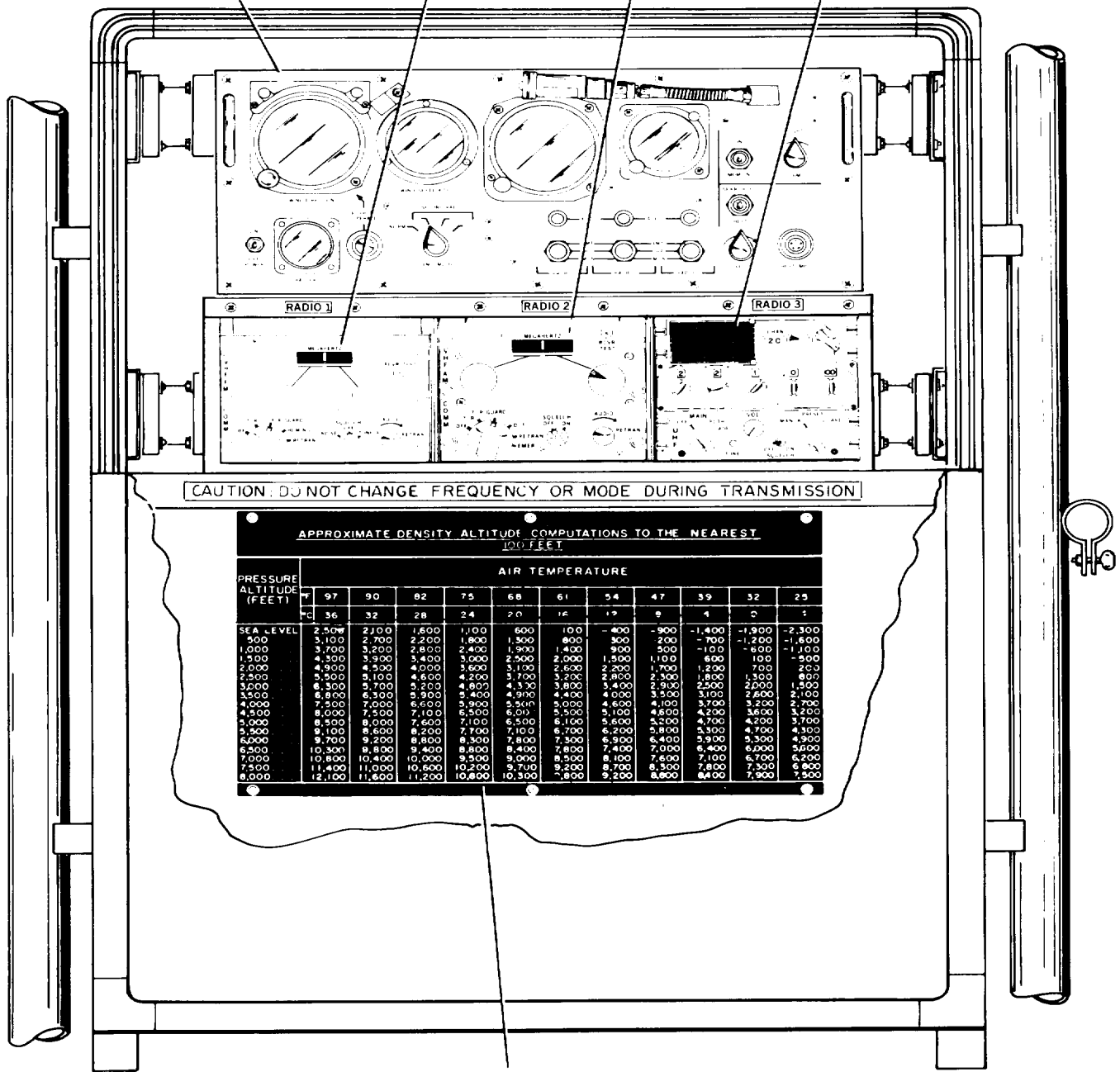
ally tunable main receiver and transmitter and fixed-tuned guard receiver. The main receiver and transmitter operate on any one of the 920 channels, spaced in 50-kHz increments in the 30.00 to 75.95 MHz frequency range. The guard receiver is fixed-tuned in the 40.0 to 42.0 MHz frequency range.

CONTROL-MONITOR  
C9921/TSQ-97

AN/ARC-114A

AN/ARC-115A

RT-1167/ARC-164(V)



CAUTION: DO NOT CHANGE FREQUENCY OR MODE DURING TRANSMISSION

**APPROXIMATE DENSITY ALTITUDE COMPUTATIONS TO THE NEAREST 100 FEET**

PRESSURE ALTITUDE (FEET)	AIR TEMPERATURE										
	°F										
	36	32	28	24	20	16	12	8	4	0	-4
SEA LEVEL	2,500	2,100	1,800	1,100	600	100	-400	-900	-1,400	-1,900	-2,300
500	3,100	2,700	2,200	1,800	1,300	800	300	200	-700	-1,200	-1,600
1,000	3,700	3,200	2,800	2,400	1,900	1,400	900	500	-100	-600	-1,100
1,500	4,300	3,800	3,400	3,000	2,500	2,000	1,500	1,100	600	100	-500
2,000	4,900	4,400	4,000	3,500	3,100	2,500	2,000	1,700	1,200	700	200
2,500	5,500	5,100	4,600	4,200	3,700	3,200	2,800	2,500	1,800	1,300	600
3,000	6,100	5,700	5,200	4,800	4,300	3,800	3,400	2,900	2,500	2,000	1,500
3,500	6,800	6,300	5,900	5,400	4,900	4,400	4,000	3,500	3,100	2,600	2,100
4,000	7,500	7,000	6,600	6,100	5,600	5,100	4,600	4,100	3,700	3,200	2,700
4,500	8,000	7,500	7,100	6,600	6,100	5,600	5,100	4,600	4,200	3,600	3,200
5,000	8,500	8,000	7,500	7,100	6,500	6,100	5,600	5,200	4,700	4,200	3,700
5,500	9,100	8,600	8,200	7,700	7,100	6,700	6,200	5,800	5,300	4,700	4,300
6,000	9,700	9,200	8,800	8,300	7,800	7,300	6,900	6,400	5,900	5,300	4,900
6,500	10,300	9,800	9,400	8,900	8,400	7,900	7,400	7,000	6,400	5,900	5,500
7,000	10,800	10,400	10,000	9,500	9,000	8,500	8,100	7,600	7,100	6,700	6,200
7,500	11,400	11,000	10,600	10,200	9,700	9,200	8,700	8,300	7,800	7,300	6,900
8,000	12,100	11,600	11,200	10,800	10,300	9,800	9,200	8,800	8,400	7,900	7,500

DENSITY ALTITUDE CHART

ELOSS 003

Figure 1-3. Air Traffic Control Facility, Partial Front View

The radio set, when operated in conjunction with this equipment is used for receiving and transmitting clear-voice or X-mode communications (when secure speech equipment is connected). The capability for retransmission of clear-voice or X-mode communication to allow usage of the radio set as a relay link is not operable when used with this equipment. For complete operation instructions for this radio set refer to TM 11-5821-259-20.

*f. Radio Set AN/ARC-115(\*).* Radio Set AN/ARC-115(\*) is an airborne, very high frequency (VHF), amplitude-modulated radio receiving-transmitting set which contains a multichannel, electronically tunable main receiver and transmitter, a fixed-tuned guard receiver, and has a direction finding capability not used with this equipment. The main receiver and transmitter operate on any one of 1,360 channels, spaced in 25 kHz increments in the 116.000 to 149.975 MHz frequency range. The guard receiver is fixed-tuned in the 119 to 124 MHz frequency range. The AN/ARC-115A has the added capability for X-mode (secure) communications. The AN/ARC-115(\*), when operated in conjunction with this equipment, is used for receiving and transmitting clear-voice communications. When the AN/ARC-115A is used (speech security equipment connected), both clear and X-mode communications are possible. For complete operation instructions and maintenance instructions for this radio, refer to TM 11-5821-260-20.

*g. Receive-Transmitter RT-1167/ARC-164(V).* This is an amplitude modulated radio transmitter-receiver operating in the 225.00 to 399.375 MHz frequency range. The RT-1167/ARC-164(V) has the capability of either clear or X-mode voice communications. Any one of 7,000 frequencies can be (manually) selected. A channel select switch selects one of 20 preset channels. The radio set has a main receiver and a guard receiver. For complete operation

and maintenance instructions refer to TM 11-5821-311-12.

*h. Antenna Mast and Boom.* The two-piece telescoping mast is attached to one side of the case by quick release pins. The antenna boom on which the antennas will be mounted is similarly attached to the other side of the case. Guy lines for stabilizing the assembled mast and boom to ground (anchor) pins are wrapped between storage hooks on the exterior of the antenna boom. Figures 1-1 and FO-2 show the assembled mast, boom and antennas in detail. Two (whip) Antennas AS-1703/ARC-54 with two Antenna Couplers CU-942B/ARC-54 and two Antennas AT-1108/ARC can be mounted on the ends of the horizontal boom attached to the top of the mast. A Wind Direction and Speed Detector ML-653/TSQ-9, a thermometer and bracket and a Radio Frequency Choke MX-9713/TSQ-97 can also be mounted on the mast. All interface to elements on the antenna boom must be made through the RF Choke.

(1) *Antenna AS-1703/ARC-54 and Antenna Coupler CU-942B/ARC-54.* For very-high frequency (FM) operation, a whip-type Antenna AS-1703/ARC-54 (see figure 1-4) is installed on Antenna Coupler Assembly CU-942B/ARC-54 mounted. Four Antennas AS-4034/TSQ-97 screwed into the assembly mounting plate serve as ground planes. One or two of these combinations can be mounted on one end of the boom, depending on the number of AN/ARC-114A Radio sets used in the particular configuration of the facility. For complete information on the antenna and coupler, refer to the TM 11-244 series of technical manuals.

(2) *Antenna AT-1108/ARC.* See figure 1-5. A blade-type Antenna

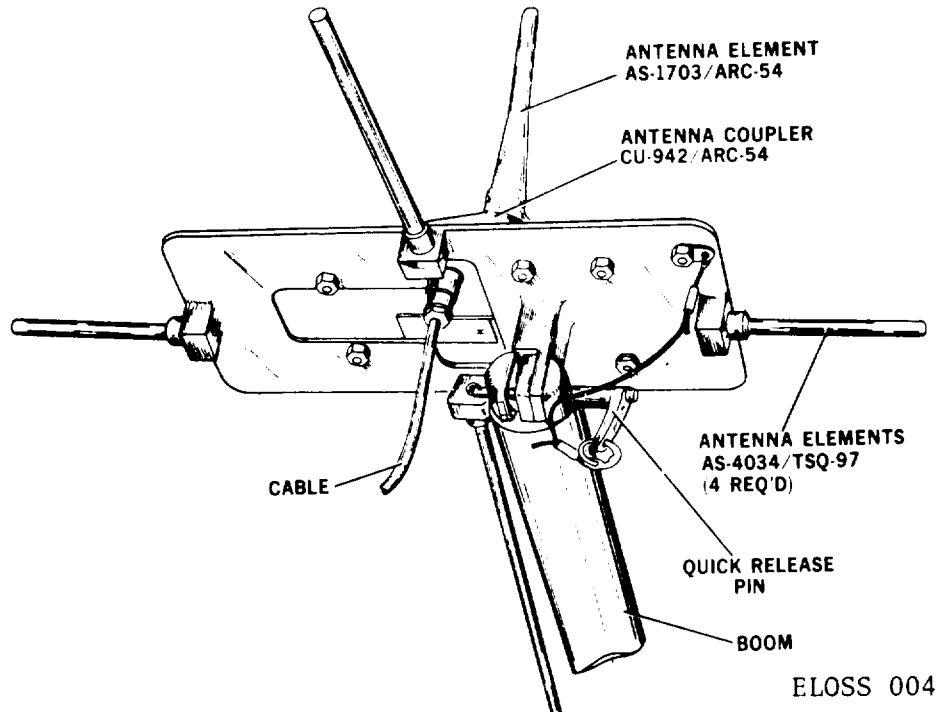


Figure 1-4. AS-1703/ARC-54 with Antenna Coupler Assembly CU-942B/ARC-54, Mounted Configuration.

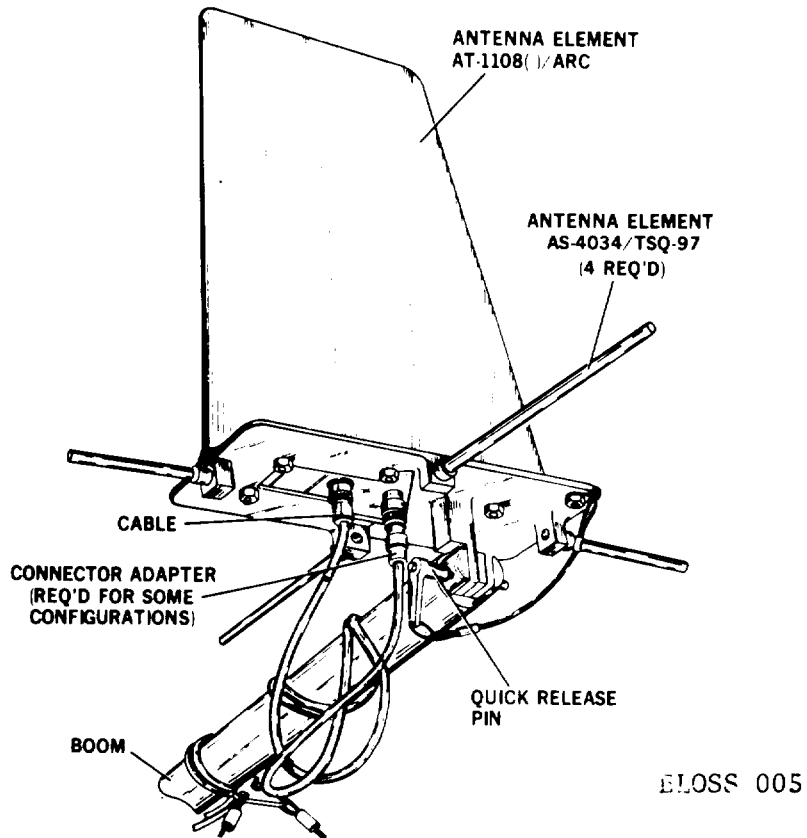
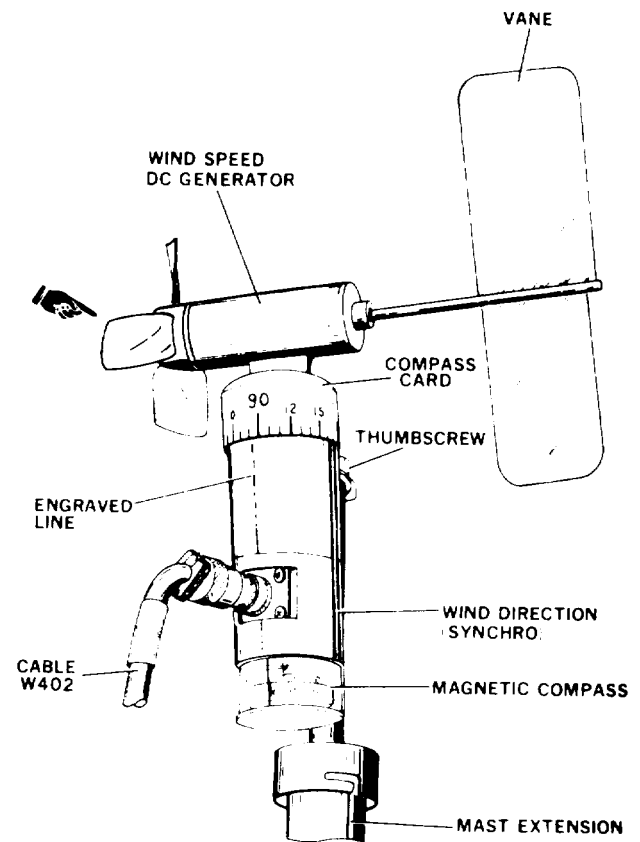


Figure 1-5. AT-1108/ARC, Antennas, Mounted Configuration.

AT-1108/ARC is mounted on the opposite end of the boom from that shown in figure 1-4. This antenna used for ultra-high frequency and very-high frequency (AM) operation is associated with Radio Set AN/ARC-115(\*) and Receiver Transmitter RT-1167/ARC-164(V). The antenna contains two separate dipoles, one for VHF and one for UHF use. A BNC/TNC adapter is provided for connection of the RT-1167/ARC-164(V) coaxial cable to the antenna. This antenna also utilizes four groundplane elements. One antenna/groundplane assembly accommodates the AN/ARC-115A and the RT-1167/ARC-164(V). A second AT-1108/ARC is supplied for use when the facility configuration requires use of two AN/ARC-115(\*) radios or two RT-1167/ARC-164(V) radios.

(3) *Wind Direction and Speed Detector ML-653/TSQ-97.* See figure 1-6. This instrument provides wind direction and speed information to the facility operator via front panel indicators. Wind speed is sensed by an impeller driven generator which generates a speed proportional voltage which is resolved to knots (KTS) on the control panel WIND SPEED meter. Wind direction is sensed when the upper portion of the detector pivots into the wind. A detachable vane allows the detector to align with the wind. A signal is generated by an internal synchro transmitter and supplied to the control monitor. Wind direction is indicated on a meter on the control panel. Wind direction can also be interpreted directly from the compass card and reference mark at the top of the assembly. A magnetic compass installed at the bottom of the unit is used for alignment of the detector with magnetic north when the facility is set up for operation.

i. *Radio Frequency Choke MX-9713/TSQ-97.* All electronic/electrical items installed on the mast are



ELOSS 006

Figure 1-6. *Wind Direction and Speed Detector ML-653/TSQ-97*

connected to the control monitor and radio sets through this choke which is attached to the mast by two clips for operation.

j. *Microphone/Headset Microphone.* Dynamic Microphone M-O80C/U provides the audio to the transmitters to monitor received audio on the speaker mounted in the control monitor. Headset-Microphone H1-337/TSQ-97 is used in lieu of the M-80C/U and speaker for two-way communications with aircraft.

1-9. Cabling Furnished. All electrical cables required for various operational configurations of the AN/TSQ-97 are shown in figure 1-7, and listed in table 1-2.

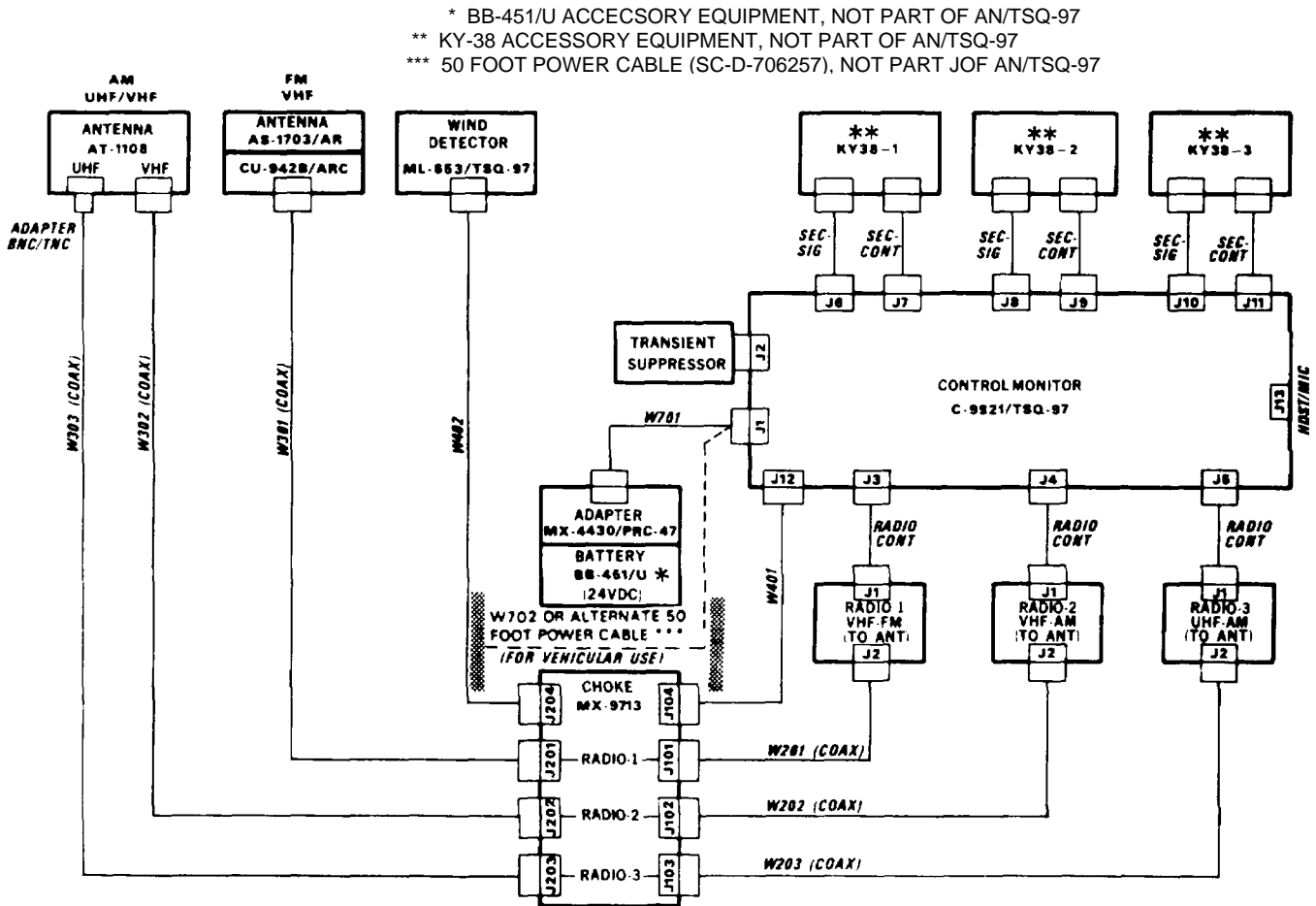
1-10. Differences Between Models. There is only one model of the AN/TSQ-97. However, specific frequency requirements for individual missions can necessitate a change in the radios used from those supplied with the facility. This may require various combinations of radios be used to satisfy mission requirements.

a. Radio Configurations. The number of individual radio types used will always be determined by

the frequency requirements of the aircraft (installed) radios that are required to communicate with the AN/TSQ-97 and whether or not X-mode communications is required. Table 1-1 lists all possible radio and antenna combinations.

b. Configuration Limitations.

(1) Because only two whip-type Antennas AS-1703/ARC-54 and two Antenna Couplers CU-942B/ARC-54 are furnished, a maximum of two Radio Sets AN/ARC-114A can be used.

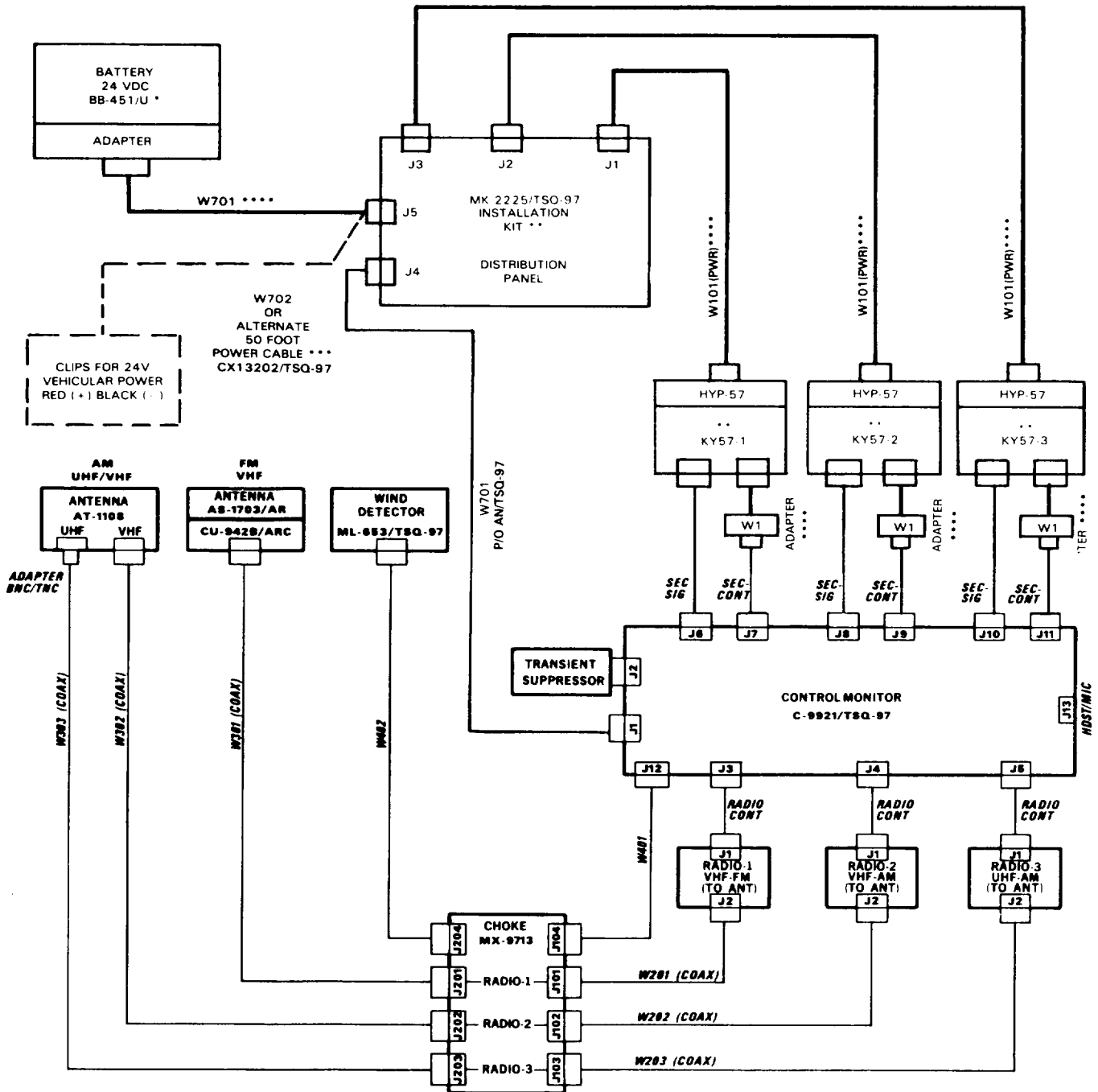


\* BB-451/U ACCESSORY EQUIPMENT, NOT PART OF AN/TSQ-97  
 \*\* KY-38 ACCESSORY EQUIPMENT, NOT PART OF AN/TSQ-97  
 \*\*\* 50 FOOT POWER CABLE (SC-D-706257), NOT PART JOF AN/TSQ-97

ELOSS 007

Figure 1-7. Cabling Diagram with TSEC/KY Security Equipment

- \* BB-451/U ACCESSORY EQUIPMENT, NOT PART AN/TSQ-97
- \*\* KY-57 ACCESSORY EQUIPMENT AND MK-2225/TSQ-97 INSTALLATION KIT, NOT PART OF AN/TSQ-97
- \*\*\* 50 FOOT POWER CABLE (SC-D-706257). NOT PART OF AN/TSQ-97.
- \*\*\*\* CABLES DENOTED IN BOLD LINES ARE PART OF MK-2225/TSQ-97 INSTALLATION KIT.



ELOSS 007

Figure 1-7A. Cabling Diagram with MK2225/TSQ-97 Installation Kit and TSEC/KY Security Equipment



Table 1-1. Radio/Antenna Configuration

Quantity of Radios			Quantity of Antennas		
AN/ARC-114 (*)	AN/ARC-115 (*)	RT-1167/ARC-164(V) or AN/ARC-116	AS-1703/ARC-54 & CU-942/B ARC-54	AT-1108(*)/ARC	AS-4043/TSQ-97 (ground- planes)
1	1	1	1	1	8
2	1	0	2	1	12
2	0	1	2	1	12
1	2	0	1	2	12
1	0	2	1	2	12
0	2	1	0	2	8
0	1	2	0	2	8

Table 1-2. Items Comprising an Operable Equipment

National Stock No.	Description	Qty	Size (inches)		
			H	L	W
5821-00-165-2970	Air Traffic Control Facility, Group Assembly OA-8879/TSQ-97	1	33	15	24
	Radio Set AN/ARC-114A	1			
	Receiver Transmitter RT-1167/ ARC-164(V)	1			
	Radio Set AN/ARC-115A	1			
	Control Monitor C-9921/TSQ-97	1	13.5	8	17.5
	Mast Assembly	1			
	Boom Assembly	1			

Table 1-2. Items Comprising an Operable Equipment  
(Items Supplied) (Cont)

National Stock No.	Description	Qty	Size (inches)		
			H	L	W
5821-00-179-3126	Antenna Coupler CU-942B/ARC-54 Mounted	2			
	RF Choke MX-9713/TSQ-97	1		5	3 (DIA)
	Thermometer Bracket Assembly	1			
5821-00-892-0895	Antenna AT-1108/ARC Mounted	2			
5821-00-082-3991	Antenna Element AS-1703(*)/ARC-54	2			
6660-01-009-4369	Wind Direction and Speed Detector ML-653/TSQ-97	1			
	Standoff (for Detector)	1			
5895-00-025-8899	Antenna Elements AS-4034/TSQ-97 (groundplanes)	12			
	Transient Suppressor	1			
6685-00-557-5316	Thermometer, MS28028-1	1			
	Cable Assembly W201 (coaxial)	1			
	Cable Assembly W202 (coaxial)	1			
	Cable Assembly W203 (coaxial)	1			
	Cable Assembly W301 (coaxial)	1			
	Cable Assembly W302 (coaxial)	1			
	Cable Assembly W303 (coaxial)	1			
	Cable Assembly W401 (Connects Wind Detector)	1			
	Cable Assembly W402 (Connects Wind Detector)	1			

Table 1-2. Items Comprising an Operable Equipment  
(Items Supplied) (Cont)

National Stock No.	Description	Qty	Size (inches)		
			H	L	W
6135-00-087-2301	Cable Assembly W701 (Connects to BB-451/U Battery)	1			
	NOTE Storage Battery BB-451/U, required for operation, is not supplied with equipment.				
	Battery Terminal Adapter MX-4430(*)/PRC-47	1			
	Cable Assembly W702 (for Vehicular Operation)	1			
	Cable Assembly, Radio Control	3			
5965-00-179-7762	Headphone-Microphone H-337/ TSQ-97	1			
	Microphone M-80(*)/U 1	1			
	Cable Assembly, Secure Signal	3			
	Cable Assembly, Secure Control	3			
	Pin (Anchors) MIL-P-501 Type II	4			

(2) Because only two blade-type Antennas AT-1108/ARC are furnished, only two AN/ARC-115(\*) Radio Sets or two RT-1167/ARC-164(V) Receiver-Transmitter sets can be used.

NOTE:

Antenna Element AS-4034/ TSQ-97 will be used to establish a groundplane for each of the

antennas, regardless of the configuration of the radios and antennas used.

1-11. Equipment Supplied. Items comprising an operable AN/TSQ-97 are listed in table 1-2. The pertinent technical characteristics for the major components of the facility are defined in paragraph 1-3a through d.

1-12. Associated Equipment Required But Not Supplied

- a. TSEC/KY-38 or TSEC/KY-57 (up to 3 ea) for X-mode communications.
- b. Installation Kit MK2225/TSQ-97 for TSEC/KY-57 interface.
- c. Storage Battery BB-4S1/U (and sufficient spares). See TM 11-6140-208-15 for battery maintenance and spare parts.
- d. Kit Battery Filler (electrolyte)
- e. Battery Charger

NOTE

An alternate 50 foot power Amplitude-cable is available for operation from a remote vehicular power source.

1-13. Tabulated Data. The following data outline the prime technical characteristics of the radio sets used with the AN/TSQ-97:

- a. *Radio Set AN/ARC-114(\*)*.

Receiver

Frequency range: 30.00 to 75.95 MHz

Number of channels: 920

Channel spacing: 50 kHz

Type of reception: Frequency-modulation

Transmitter

Frequency range: 30.00 to 75.95 MHz

Power output: 6 watts, minimum

Output check: Audio sidetone signal

Power Requirements

Normal voltage: 24 volts dc negative ground

Input power:  
 Receive - 17.0 watts (max)  
 Transmit - 85.0 watts (max)

- b. *Radio Set AN/ARC-115(\*)*.

Receiver

Frequency range: 116.00 to 149.975 MHz

Number of channels: 1360

Channel spacing: 25 kHz

Type of reception: Amplitude-modulation

Transmitter

Frequency range: 116.00 to 149.975 MHz

Power output: 6 watts, minimum

Output check: Audio Sidetone signal

Power requirements

Voltage: 24 volts, negative ground

Input power:  
 Receive - 21 watts (max)  
 Transmit - 85.0 watts (max)

- c. *Receiver-Transmitter RT-1167/ARC-164(V)*

Receiver

Frequency range: 225.00 to 399.975 kHz

Number of channels: 7,000

Channel spacing: 0.025 MHz

Type of reception: Amplitude-modulation

d. *Wind Direction and Speed Detector*  
ML-653/TSQ-9.

Transmitter

Frequency range: 225.00 to 399.75 kHz.

Power output: 3 watts minimum

Output check: Audio sidetone signal

Wind direction indication

Range: 0° to 3600

Accuracy: 5°

Power requirements:  $26 \pm 1.5$  volts ac

Power requirements

Nominal:  $\pm 24$  volts dc

Input power:

Receive - 50 watts (max)

Transmit - 150 watts (max)

Wind speed

Range: 0 to 50 knots

Accuracy:  $\pm 3$  knots, 3-17 knots,  $\pm 4$  knots 18-50 knots

**Change 2 1-14**

## CHAPTER 2

## SERVICE UPON RECEIPT AND INSTALLATION

---

**Section I. SERVICE UPON RECEIPT**

2-1. Unpacking. There are no special instructions applicable to unpacking this equipment. The AN/TSQ-97 is shipped in two separate disposable corrugated boxes. Carefully open the shipping boxes and remove the equipment case and mast and boom. Check to see that all components listed in table 1-2 were received.

2-2. Inspection. Inspect equipment to see if damage was incurred during shipment. Check for damaged front panel controls. Loosen eight winged fasteners and lower the rear panel of the control monitor. Inspect interior connections and circuit boards to see that they are secure. Note any damage and conditions which might jeopardize using the equipment if not attended to.

a. *Damage.* Report damage on SF 364 as defined in paragraph 1-3b.

b. *Incomplete Shipment.* Check equipment against packing list to see if shipment is complete. Report any discrepancies in accordance with instructions of paragraph 1-3c. If packing list is not available, check items received against table 1-2 here-in or against the basic issue items list for the equipment.

c. *Modifications.* Check to determine if equipment has been modified by a Modification Work Order (MWO). Modifications resulting from a MWO will show the MWO number on the nomenclature plate. Check to see if all applicable MWO's have been incorporated. Current MWO's are listed in DA-Pam 310-4. If the equipment has been modified, check

associated publications to see if required changes have been made.

2-3. Preparing Storage Battery BB-451/U for Use. Obtain Storage Battery BB-451/U and sufficient spares to support prolonged operation of the facility. The battery must be filled with electrolyte and charged prior to use. Refer to TM 11-6140-208-15 for complete procedures on servicing the battery.

2-4. Tools and Test Equipment Required for Installation. The only tool required is a hammer for driving the guy line anchor pins into the ground.

**WARNING**

Four people are required to carry the equipment to the selected site.

2-5. Packaging for Limited Storage or Shipment. Refer to SB 38-100 for materials and procedures used in packing equipment for limited storage or shipment. Always inventory the facility prior to storage to preclude unnecessary delays when the equipment is put back into service.

**WARNING**

**DO NOT STORE OR SHIP THE AN/TSQ-97 WITH STORAGE BATTERY BB-451/U INSTALLED.**

**Change 1 2-1**

## Section II. INSTALLATION INSTRUCTIONS

2-6. Site Information. The site selected for operating the AN/TSQ-97 will primarily depend on the configuration of the airfield and surrounding area. The site should be level and afford the operator full view of aircraft, landing, taxi, takeoff areas, ramps, parking areas and airfield perimeter. This equipment is not actually installed as such, but (is set-up for (temporary) use where needed. The facility can be set up and in operation in about 10 minutes.

a. Because the antennas are mounted on a boom and mast assembly physically attached to the equipment case, their height is limited. Consider the following in site selection: following in site selection:

(1) Radio signals are absorbed and sometimes reflected by nearby obstructions, such as, hills, metal buildings, bridges, etc that extend above the height of the antenna. In general, transmitted signals have a greater range when the antenna is as high above ground and surroundings as possible. Transmission and reception usually are best over level ground or water. Telephone lines and powerlines in the immediate area can also cause interference and should be avoided if possible.

(2) Because of line-of-sight propagation, characteristics of VHF and UHF, and the distances involved in communications between a ground station and airborne craft, the antennas should be elevated as much as possible.

b. *Wind Direction and Speed Detector ML-653/TSQ-97.* This detector is also mounted on the antenna mast, therefore, consider the following when siting the facility.

(1) Of primary concern for safe aircraft control operations is accurate reporting of wind speed and direction. The detector must be located in an area free from obstructions which might interfere with the free movement of wind over the detector.

(2) Wind direction will normally be reported as a magnetic compass bearing from the indicator on the Control Monitor front panel. The deflection of the compass needle or card from a position of true magnetic north as a result of local magnetic disturbances must be taken into account when reporting wind direction.

2-7. Equipment Storage During Transit. All items comprising an operable AN/TSQ-97 are stored in the equipment case or in the metal (mast and boom) carrying handles. The BB-451/U is not supplied as a part of the facility; however, space is provided to place the battery during limited transportation. Figure 2-1 is a rear view of the facility showing items stored in the equipment case proper.

### WARNING

Storage Battery BB-451/U must not be installed in the facility during prolonged transportation or storage.

a. *Other Storage.* The vertical position (the antenna mast) is made up of two sections, one inside of the other. The exterior section is metal. The interior, telescoping section is fiberglass. When not telescoped, the mast is attached to the case for a carrying handle. Stored in the metal mast are two whip-type Antennas AS-1703/ARC-54. To remove these items, remove the mast end twist-lock cap.

**Change 1 2-2**

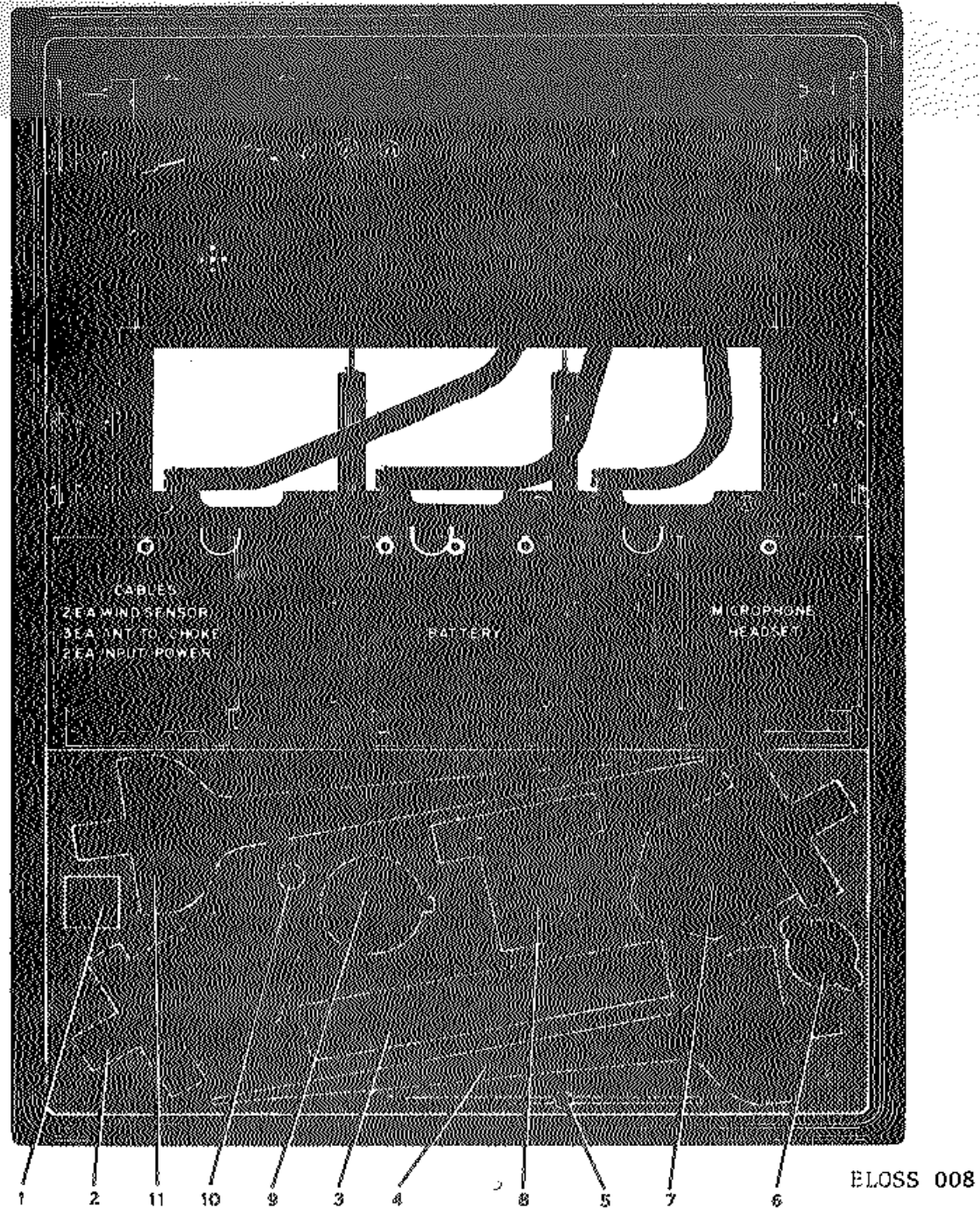


Figure 2-1. Air Traffic Control Facility, Group Assembly  
OA-8879/TSQ-97, Rear View.

- |   |  |
|---|--|
| <ul style="list-style-type: none"> <li>1. Thermometer Bracket</li> <li>2. Coupler Assembly Mounted (CU-942B/ARC)</li> <li>3. Operator's Manual TM 11-5895-800-12</li> <li>4, 11. Antenna Assembly, AT-1108/ARC</li> <li>5. Vane for Detector ML-653/TSQ-97</li> </ul> | <ul style="list-style-type: none"> <li>6. Thermometer</li> <li>7. Coupler Assembly Mounted (CU-942B/ARC-54)</li> <li>8. Wind Detector ML-653/TSQ-97</li> <li>9. Choke, RM, MX-9713/TSQ-97</li> <li>10. Standoff</li> </ul> |
|---|--|



b. Front Cover Stored Items. Stored within the front cover are 6 cables for X-mode communications use, 4 anchor pins and 12 Antenna Elements AS-4034/ TSQ-97. See figure 2-2.

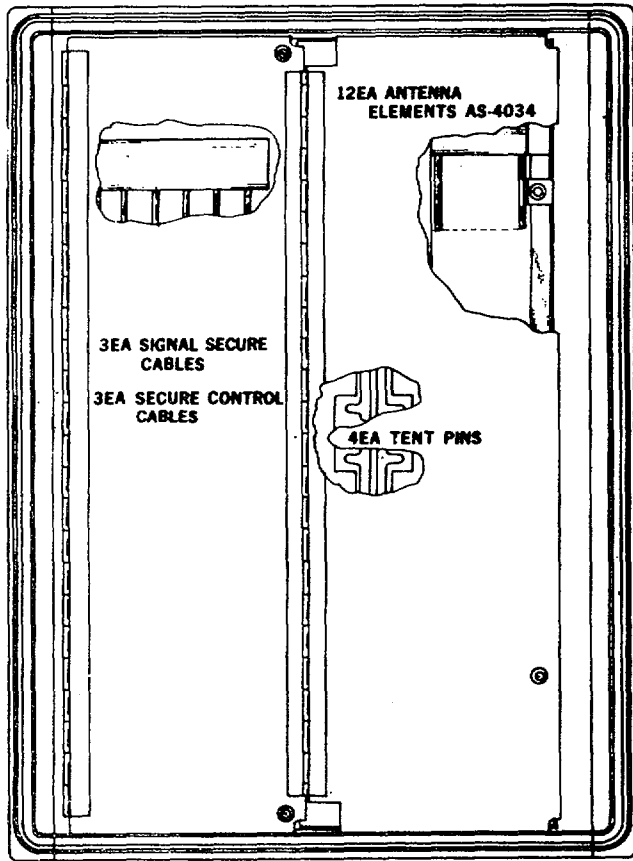


Figure 2-2. Front Cover Storage Items

2-8. Systems Planning. To properly operate and maintain the facility requires a minimum of planning. The using activity should be aware of what aircraft (frequencies) may have to be used and assure the proper receiver/ transmitters are installed. Units are available and operable. Also make sure of the following:

a. Spare fully-charged Storage Batteries BB-4S1/U are available (depending on communications load a battery will last about 8 hours).

(1) Filler kits (electrolyte, Potassium Hydroxide) are readily available. See TM 11-6140-208-15.

(2) Battery charger compatible with BB-451/U is available.

b. Sufficient spare parts are on hand.

c. If X-mode communications will be required, ascertain that Communications Security Equipment TSEC/KY-38 is available with charged batteries and ample spares, or that TSEC/KY-57 with MK-2225/TSQ-97 installation kit is available.

2-9. Facility Setup (Installation). The procedures provide a logical step by-step sequence for placing the facility in operation once the site of operation has been established. When assembled as shown in figure 1-1 and FO-2, the maximum height of the facility is 12 feet.

a. Assembly Mast and Boom. Assemble the antenna mast and boom as defined in (1) through (10) below.

(1) Remove four quick-release pins that secure the carrying handles to the equipment case. Remove the handles.

(2) Set the case in an upright position. Press red button on pressure-relief valve on side of the case. Release 10 latches and remove front and back covers.

(3) Remove the twist-lock cap from the bottom of the mast and remove the AS-1703/ARC--54 Antennas. If only one AN/ARC-114A is being used, leave one element in the mast and replace the cap. Lay the elements aside in a safe place until needed.

**CAUTION**

To prevent damage to the antenna remaining in the mast, the mast extension should not be lowered into the mast once it has been extended unless the stored antenna is first removed.

(4) Remove the quick-release pin from the top of the mast.

(5) Pull the mast extension out of the mast approximately 8 inches until a .25 diameter spotface appears. Align mast extension holes with mast holes 2 inches from the top of the mast and insert quick-release pin.

(6) Secure the mast to the case (either side) by inserting the lower two brackets on the mast into the brackets on the side of the case. Engage the quick-release pins.

(7) Unwind the guys from the boom and assemble the boom to the top of the mast extension. The pin on the inside of the fixed portion of the hinged

clamp mates with a hole located 5 inches from the plug in the mast extension. Tighten the thumbscrews.

(8) Shorten the guys so that the keepers are approximately halfway and hook the triangular shaped brackets on the two inner hooks on the boom.

(9) Insert a stake in each of the other brackets on the guys and drive the stakes into the ground. Refer to figure 2-3 for recommended guy positioning.

**NOTE**

If, due to extremely hard ground or excessive rocks, or the earth is spongy or soft, use any suitable means to anchor the guy lines.

(10) Tighten the guys so that the mast and boom are held securely in position. The guys will be loosened to raise the mast to its full height later on in this procedure.

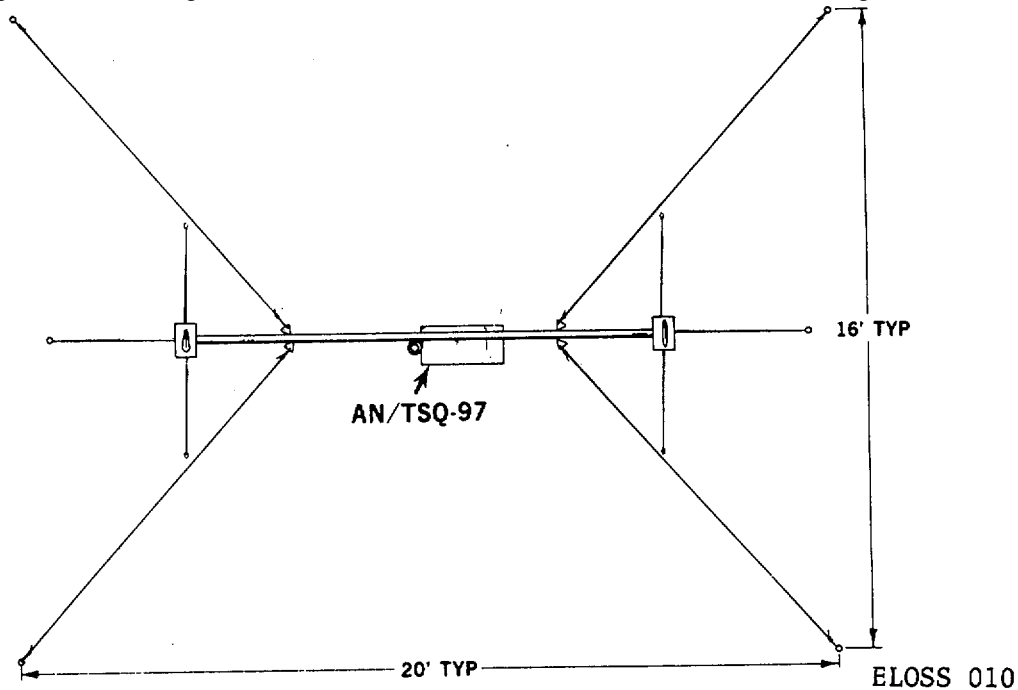


Figure 2-3. Guy Line and Anchor Pin Positioning.

b. Antenna Mounting. Follow these steps to mount the antennas to the boom.

(1) Assemble Antenna Couplers CU-942B/ARC-54 mounted on a plate to one end of the mast as shown in figure 1-4.

(2) Assemble Antennas AT-1108/ARC (mounted on a plate) to the other end of the boom as shown in figure 1-5.

**CAUTION**

Do not remove the BNC/TNC connector adapter Amphenol part numbers 79675, Pomona Electronics part numbers 38440 from the UHF connector on the antenna. This adapter is required when using the RT-1167/ ARC-164(V).

(3) Screw (fingertight) four Antenna Elements AS-4034/TSQ-97 (groundplanes) into the mounting plate as shown in figure 1-4. Screw Antenna AS-1703/ARC-54 (whip type) into the threaded hole on Antenna Coupler CU-942B/ARC-54.

(4) Screw four groundplane elements into the AT-1108/ARC antenna mounting plate as shown in figure 1-5.

(5) Refer to figure 1-7. Connect the appropriate cables to the antennas. Connect the cables from the radios (ANTENNA INPUT J2) to the bottom end of the RF choke as shown. The antenna cables will be attached to the top of the choke after the mast is extended.

**NOTE**

Make sure antenna cables are attached to proper radio, as overload protection circuits in the radios may cause them to

shut off due to improper antenna loading. Loop all cables around mast and boom to prevent damage to connectors during windy or icing conditions.

c. Mounting Wind Direction and Speed Detector ML-653/TSQ-97. Remove the detector, vane and standoff from the rear storage compartment (see figure 2-1). Insert the vane connection end into the detent socket in the end of the wind speed generator as shown in figure 1-6. Mount the standoff on top of the antenna mast.

(1) Attach the detector assembly to the top of the standoff as shown in figure 1-6.

(2) Connect cable W402 to the detector and the RF choke as shown in the cabling diagram figure 1-7. Orient the reference mark on the detector housing to the magnetic North as indicated on the magnetic compass. Tighten the thumbscrew.

**CAUTION**

Each time the position of the ML-653/TSQ-97 is changed either by accidentally bumping the equipment case, repositioning the equipment case, or repositioning the ML-653/TSQ-97, the ML-653/TSQ-97 must be realigned with magnetic North.

d. Extending Mast.

(1) Have one person hold the mast to keep it from tipping over and loosen the guys by moving the keepers all the way to the stakes.

(2) Remove the quick-release pin from the top of the mast and pull out the mast until a .25 diameter spotface

is exposed to help align the holes in both mast and mast extension. Insert the quick-release pin through mast and extension.

(3) Tighten the guy lines evenly so that the mast and boom are held securely in place.

**CAUTION**

Hereafter, each time the position of the ML-653/ TSQ-97 is changed, such as by repositioning the equipment case or wind detector, the wind detector must be realigned with magnetic North.

e. Final Assembly. Attach clip on Radio Frequency Choke MX-9713/TSQ-97 to the mast extension. Attach cables from the antennas to the top of the choke as shown in figure 1-7. Clamp the thermometer to the mast just below the choke, so that it is conveniently visible to the operator. Check that the radio control cables are connected between the radios and the associated connector on the control monitor. Refer to figure 1-7 and figure FO-1. Connect the battery cable to Storage Battery BB-451/U and the POWER IN connector on the rear panel of the C-9921/TSQ-97. The battery can be left in its storage position or removed and set on the ground. Refer to paragraph 2-10 if Vehicular power is to be used instead of the battery.

**NOTE**

The rear cover can be leaned against the top of the equipment case and attached at the top to act as a rain shield if desired.

**CAUTION**

To avoid damage to transistors and integrated circuits, make sure that the POWER ON/OFF switch on the control monitor and the function selector switch on each radio is set to OFF before making or changing power cable connections. Check the source voltage and polarity before applying power to the facility.

2-10. Operation From Vehicular Power. Auxiliary power cable W702 is provided for operating the facility from a vehicle power system, in the absence of other battery power. Vehicular power may also be obtained from a remote source by use of an alternate 50 foot power cable CX13202/TSQ-97, not included with the AN/ TSQ-97 facility. Connect one end of the cable to the POWER IN connector J1. Polarity must be observed when connecting the alligator clips of the cable to the battery. Always determine which is the positive battery terminal and which is the negative terminal prior to attaching the clips. Attach red clip to the positive terminal. Attach the black clip to the negative terminal. The transient suppressor must always be connected to J2 on the rear panel when using vehicle power.

**CAUTION**

Failure to observe polarity can result in damage to circuit components when the facility is turned on. Do not energize the facility if the BATTERY meter indicates less than 20 volts or more than 30 volts.

2-11. X-Mode Communications. If X-mode communications are desired, connect Voice Security Equipment TSEC/KY-38 to the appropriate radio connectors using secure signal cables and secure control cables as shown in figure 1-7. When operating the TSEC/KY-38 equipment, the units are installed on top of the AN/TSQ-97 facility. Operating and handling instructions for TSEC/KY-38 are contained in Publication KAO-153A/TSEC (RP-2). Xmode communications can also be accomplished using Voice Security Equipment TSEC/KY-57, in the vehicular configuration with the MK-2225/TSQ-97 installation kit. The TSEC/KY-57 vehicular configuration requires the use of Vehicular

Power Adapter HYP-57/TSEC for operation. See figure 1-7 for appropriate cabling information. When operating the TSEC/ KY-57 equipment, the units are mounted on the MK-2225/TSQ-97 installation kit base and the installation kit base is mounted on top of the AN/TSQ-97 facility as shown in figure 1-1. The installation kit is mounted with the rear of the TSEC/KY-57 equipment facing the front of the AN/TSQ-97 facility. Power cables and adapter cables used with the MK2225/TSQ-97 installation kit are stored in the installation kit cover. Operating and handling instructions for TSEC/KY-57 are contained in Publication TM 11-5810-256-12.

**2-8 Change 2**

## CHAPTER 3

## OPERATING INSTRUCTIONS

## Section I. OPERATOR'S CONTROLS AND INDICATORS

3-1. Introduction. This section defines the function of each operating control, indicator and connector accessible for operation of the facility. Also defined are restrictions to (improper) switch settings or operator actions which can cause equipment damage.

3-2. Damage From Improper Settings. Observe the following CAUTIONS and WARNINGS to preclude equipment damage and personnel hazard.

**WARNING****DANGEROUS CHEMICALS ARE USED  
IN SILVER-ZINC BATTERIES**

The electrolyte used in silver-zinc batteries (BB-451/U) contains potassium hydroxide (KOH), which is a caustic chemical agent. Serious and deep burns of body tissue will result if the electrolyte comes in contact with the eyes or any part of the body. Use rubber gloves, rubber apron, and protective goggles when handling the electrolyte. If accidental contact with the electrolyte is made, use ONLY clean water and immediately (seconds count) flush contaminated areas. Continue flushing with large quantities of clean water for at least 15 minutes. Seek medical attention without delay.

**WARNING**

DO NOT SEAL ACTIVATED BATTERIES IN AIRTIGHT CONTAINERS SUCH AS TRANSIT CASES FOR AN EXTENDED TIME, AS HYDROGEN OUTGASSING MAY CREATE AN EXPLOSIVE ENVIRONMENT.

**WARNING**

DO NOT MIX SULPHURIC ACID AND KOH

The electrolyte used in silver-zinc batteries (BB-451/U) reacts violently to the sulphuric acid used in the more common lead-acid types of batteries. DO NOT add sulphuric acid electrolyte to the battery; the mixing of the acid and KOH electrolytes will cause a violent reaction which could result in the splattering of the mixture into the eyes and onto the skin. Every effort must be made to keep silver--zinc batteries as far away as possible from lead-acid batteries. Do not use the same tools and materials such as screwdrivers, wrenches, syringes, hydrometers, and

gloves for both types of batteries. Any trace of acid or acid fumes will permanently damage silver-zinc batteries on contact.

**WARNING**

Storage Battery BB-451/U uses dangerous chemicals which can cause severe burns if personnel fail to observe safety precautions. Report to hospital or first aid station for treatment. Tell doctor you have been contaminated with Potassium Hydroxide (KOH).

**CAUTION**

Do not change either the frequency selector setting or the mode switch setting on any of the radio sets when transmitting; damage to the radio set can result.

**CAUTION**

When operating from a vehicular power system, the function selector switch on the individual radio sets should be set to OFF prior to starting or stopping the vehicle engine.

**CAUTION**

When facility is to be operated from a vehicular power system, always determine supply polarity prior to connecting the

alligator clips. Connect red clip to positive (+) terminal. Connect black clip to negative (-) terminal. Failure to observe polarity will result in damage to transistors and integrated circuits when the facility is powered up.

3-3. Controls and Indicators.

a. Front Panel Control and Indicators. Figure 3-1 shows all front panel controls and indicators used by the facility operator. Table 3-1 defines the function of the controls and indicators.

b. Rear Panel Connectors, Control and Indicator. Figure 3-2 shows a rear view of the Control Monitor and table 3-2 defines the function of each connector, switch or indicator. Also defined are the rear connectors and protective devices for the individual radio sets.

c. Radio Set AN/ARC-114(\*), Front Panel Controls and Indicator. The radio front panel contains all controls and indicators required to operate the radio set. Figure 3-3 shows the radio front panel and table 3-3 defines the functions.

d. Radio Set AN/ARC-115(\*) Control and Indicators. The radio front panel contains all controls and indicators required to operate the radio as shown in figure 3-4 and defined in table 3-4.

e. Receiver-Transmitter RT-1167/ ARC164(V), Controls and Indicators. The radio front panel contains all controls and indicators required for operation. Figure 3-5 shows the front panel and table 3-5 defines the functions.

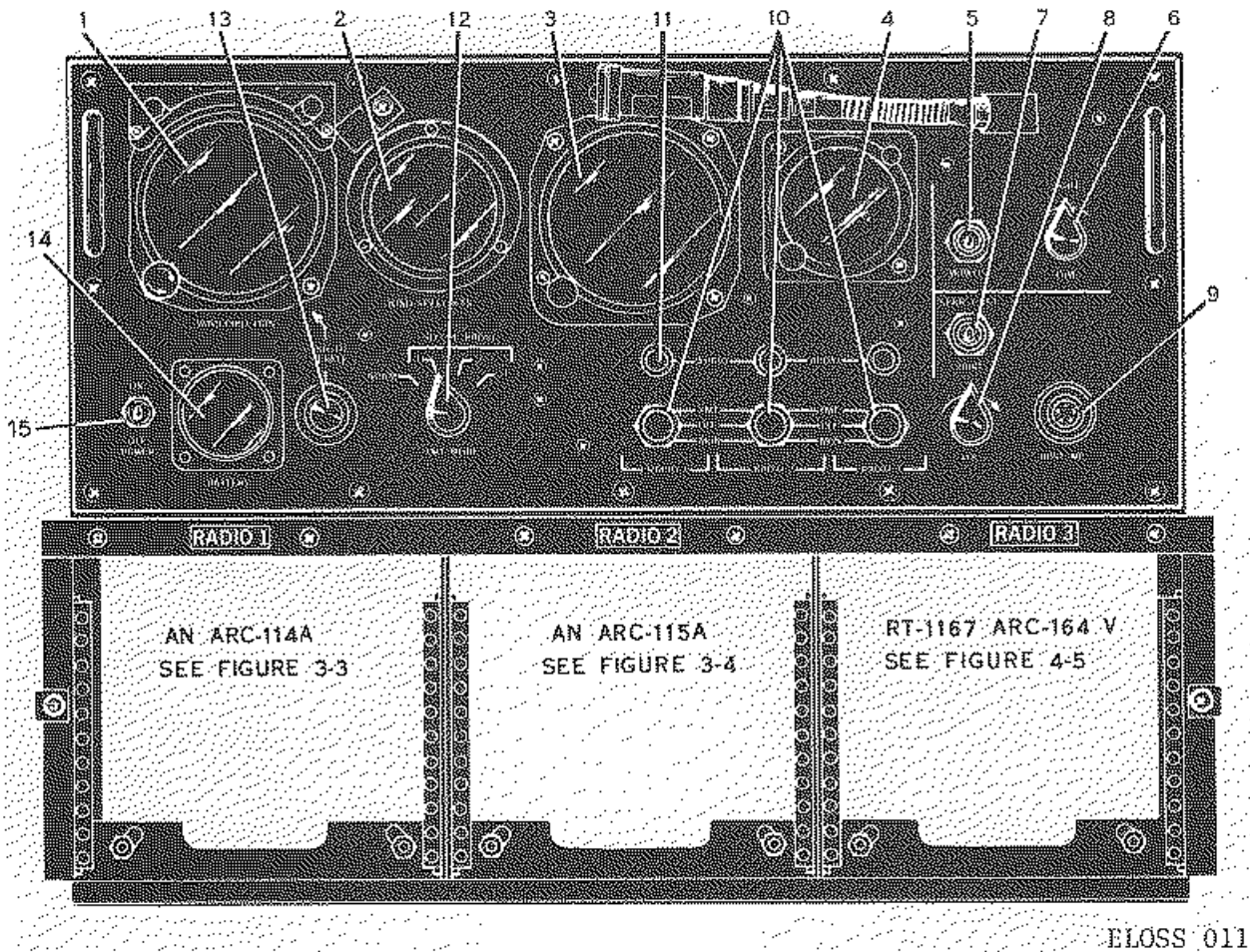


Figure 3-1. C-9921/TSQ-97, Front Panel Controls and Indicators

Table 3-1. Controls, Connections and Indicators

Fig. 3-1 Index No.	Control Name	Position	Function
1	WIND DIRECTION- (meter) indicator	-	Calibrated to indicate wind direction in degrees from magnetic North reference. Operates when PUSH TO OPERATE switch/indicator is pressed.
2	WIND SPEED (KTS) meter wind speed in knots.	-	Meter calibrated to indicate
3	ALTIMETER	-	Provides barometric pressure settings for operating aircraft.



Fig. 3-1 Index No.	Control Name	Position	Function
4	Real time clock	-	Eight day wind-up clock with sweep hand stop watch capability.
5	LIGHTS three-position toggle switch	ON	Panel illuminated from flexible-shaft lamp assembly. Radio panel lamps ON.
		OFF	Radio panel lights and flexible-shaft lamp assembly not lit.
		MOM-ON	Flexible-shaft lamp and radio panel lights are on as long as switch held to MOM-ON.
6	DIM (variable control)	CCW CW	Lamps dim (when on). Lamps maximum brightness (when on).
7	SPKR/HDST-HDST, two-position toggle switch	SPKR/HDST	Operator selected audio to be heard from speaker and headsets simultaneously.
		HDST	Audio heard only in operator's headset.
8	VOLUME variable	CCW control	Communications loudness from speaker and headset set to minimum level.
		CW	Maximum volume.
9	HDST/MIC, twist-lock connector	-	Connects operator's headset/microphone or M-80C/U microphone to facility.
10	RADIO 1, RADIO 2, RADIO 3, three-position toggle switches however, audio processing path to speaker and headset is interrupted.	OFF	Associated radio set is in the standby mode and cannot transmit. Radio is still energized. Radio can receive,

Figure. 3-1 Index No.	Control Name	Position	Function
10 (Cont)		XMT	Associated radio set can transmit and receive.
		MON	Associated radio set can only receive.
11	RADIO 1, RADIO 2, RADIO 3, AUDIO lamps (green lens with push-to-test feature)	lit	Indicate the associated radio set is receiving or transmitting.
12	XMT MODE, four position rotary switch	NORM	Security (X-mode) transmit not being used. All radio sets transmit clear text. Security equipment can be hooked up, but transmit function is bypassed by relay switching on NORM. Secure and clear receive functions are possible with TSEC in cypher. If in plain, only clear reception is possible.
13	PUSH TO OPERATE, alternate action switch-indicator (lit when ON) synchros.	Pressed down (ind lit)	Lights WIND DIRECTION indicator panel lights and initiates 26 volts ac to energize WIND DIRECTION
14	BATTERY (meter) 0 50V dc	-	Indicates battery voltage under loaded and no-load conditions.
15	POWER ON/OFF switch circuit breaker (15 AMP)	ON	Applies power supply voltage to internal circuitry and radio sets.

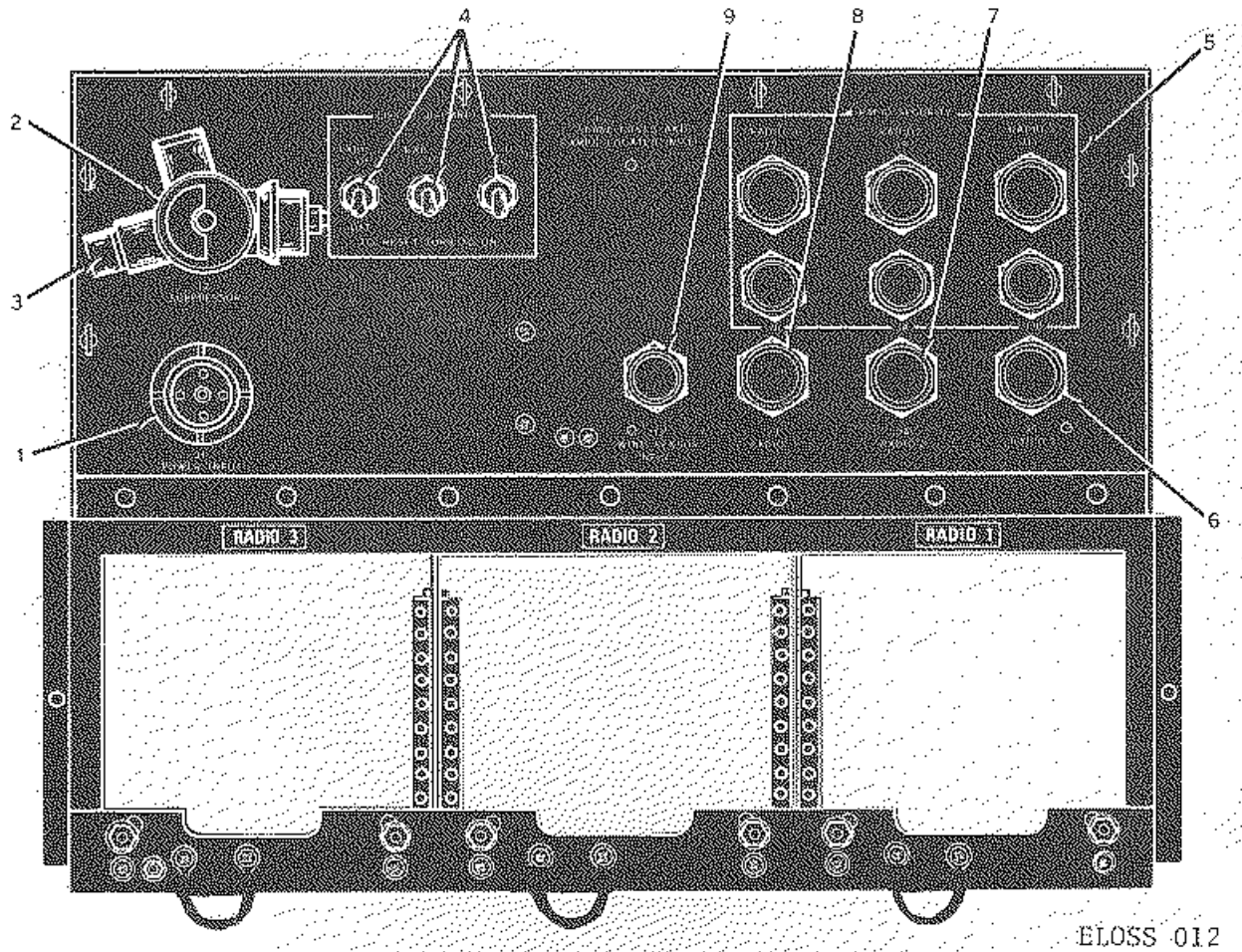


Figure 3-2. C-9921/TSQ-97, Rear Views

Table 3-2. C-9921/TSQ-97, Rear Panel Operator Controls and Indicator

Fig. 3-1 Index No.	Control Name	-	Position      Function
1	POWER IN, connector J1	-	Connects battery cable W701, or auxiliary power cable W702 (vehicular power).
2	TRANSIENT SUPPRESSOR (connects to J2)	-	Used to damp surges and transient electrical inter- ference when operating from a vehicular power source.

Table 3-2. C-9921/TSQ-97, Rear Panel Operator Controls and Indicator (Cont)

Figure. 3-1 Index No.	Control Name	Position	Function
3	Red indicator lamp- (P/O index 2)		When lit, indicates transient suppressor is no longer serviceable and must be changed.
4	CIRCUIT BREAKERS		
	RADIO 1	ON	5 amp circuit breaker and ON/OFF switch for radio 1. Reset by pushing lever to ON.
	RADIO 2	ON	6 amp circuit breaker for radio 2. Reset by pushing lever to ON.
	RADIO 3	ON	6 amp circuit breaker and ON/OFF switch for radio 3. Reset by pushing to ON.
5	RADIO SECURITY CONNECTORS		
	RADIO-1 connector J6	-	Signal connector for security equipment.
	RADIO-1 connector J7	-	Control connector for security equipment.
	RADIO-2 connector J8	-	Signal connector for security equipment.
	RADIO-2 connector J9	-	Control connector for security equipment.
	RADIO-3 connector J10	-	Signal connector for security equipment.
	RADIO-3 connector J11	-	Control connector for security equipment.
6	RADIO 3 connector receptacle J5	-	Connects radio 3 to control monitor via radio control cable.

Table 3-2. C-9921/TSQ-97, Rear Panel Operator Controls and Indicator (Cont)

Figure. 3-1 Index No.	Control Name	Position	Function
7	J4 RADIO 2 Connector	-	Connection for radio 2 control cable. Receptacle
8	J3 RADIO 1 Connector Receptacle	-	Connection for radio 1 control cable.
9	J12 WIND SENSOR INPUT	-	Connection for inputs from wind sensor. Connects from RF choke.
-	RADIO SET REAR PANEL CONNECTORS:	-	
-	AN/ARC114 (*)		
-	J1	-	Signal, control, and power application.
-	J2	-	Connector for FM antenna.
-	J3, J4	-	Homing antenna inputs not used with AN/TSQ-97.
-	AN/ARC115 (*)		
-	J1	-	Signal, control, and power application.
-	J2	-	AM-VHF antenna connector.
-	RT-1167/ARC-164 (V)	-	
-	J1	-	Signals, control, and power application.
-	J2	-	AM-UHF antenna connection.
	<b>3-8 Change 1</b>		

ELOSS 014

ELOSS 013

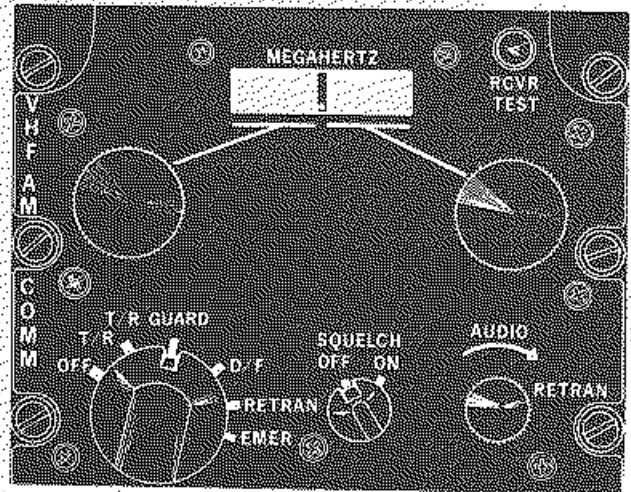
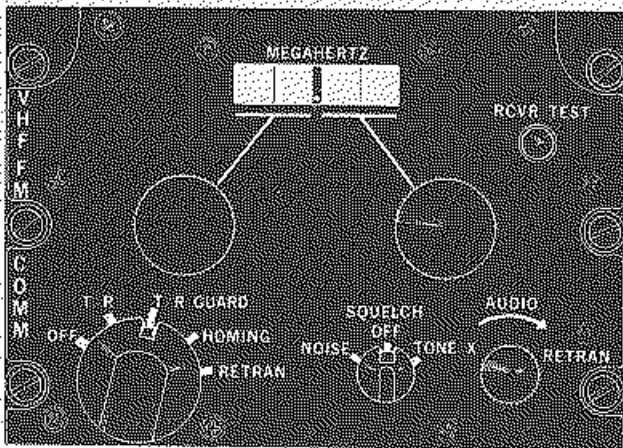


Figure 3-3. AN/ARC-114( ) Operator

Figure 3-4. AN/ARC-115( ) Operator  
Controls and Indicators

Controls and Indicators

Table 3-3. AN/ARC-114A Front Panel Controls and Indicators

Index (see fig. 3-3)	Position	Function
MEGAHERTZ indicator	-	Indicates frequency to which main receiver and transmitter are tuned.
MEGAHERTZ rotary control on left side	-	Tunes main receiver/transmitter in 10 MHz and 1 MHz steps as indicated by first two digits of MEGAHERTZ indicator (guard receiver is fixed tuned).
KILOHERTZ rotary control on right side	-	Tunes main receiver/transmitter in 100 KHz and 50 KHz steps as indicated by last two digits of MEGAHERTZ indicator.
RCVR TEST pushbutton	-	When pressed, injects a canned signal into the main receiver to produce an audible indication of main receiver performance.

Table 3-3. AN/ARC-114A Front Panel Controls and Indicators (Cont)

Index (see fig. 3-3)	Position	Function
Function selector five position rotary switch:	-	Determines operating mode of radio mode:
	OFF	Removes power (except lighting) from radio set.
	T/R	Radio set operates as a transceiver on main channels indicated on MEGAHERTZ indicator. Guard receiver is inoperative.
	TR/GUARD	Same as for TR except guard receiver also operates.
	HOMING	Not used with AN/TSQ-97.
	RETRAN	Not used with AN/TSQ-97.
SQUELCH rotary selector switch:	NOISE	Sets threshold for noise squelch.
	OFF	Squelch disabled.
	TONE/X	Tone squelch enabled.
AUDIO rotary control	Variable	Adjusts the radio set audio output. Leave adjusted to the point where the AUDIO indicator light on the control monitor lights when receiving.

Table 3-4. AN/ARC-115A Front Panel Controls and Indicators

Index (see fig. 3-3)	Position	Function
MEGAHERTZ indicator	-	Indicates frequency to which main receiver and transmitter are tuned.

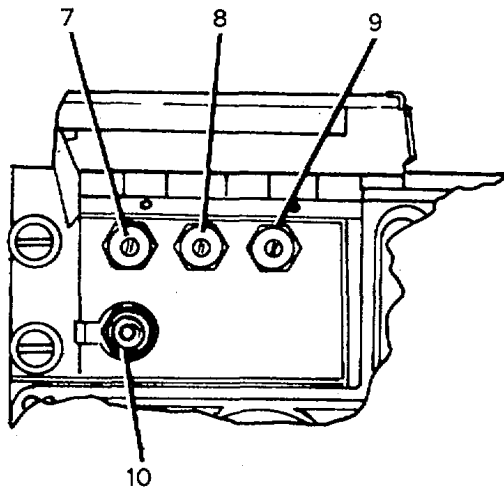
Table 3-4. ANTARC-115A Front Panel Controls and Indicators (Cont)

Index (see fig. 3-3)	Position	Function
MEGAHERTZ control on left side	rotary	Tunes main receiver/transmitter in 100-MHz, 10-MHz, and 1-MHz steps as indicated by the first three digits of the MEGACYCLES indicator. (Guard receiver is fixed-tuned.)
KILOHERTZ control on right side	rotary	Tunes main receiver/transmitter in 100-kHz and 25-kHz steps as indicated by last three digits of MEGACYCLES indicator. (Guard receiver is fix-tuned.)
RCVR TEST pushbutton		When pressed, injects a noise signal into main receiver to provide an audible indication of proper receiver performance.
Function selector switch five position rotary:		Determines operating mode of radio set.
	OFF	Removes power; radio set is inoperative.
	TR	Provides for radio set operation as a transceiver on main channels indicated on MEGACYCLES indicator. (Guard receiver is inoperative.)
	TR/GUARD	Same as T/R above plus reception of guard channel.
	DF	Direction Finding Not used AN/TSQ-97.
	RETRAN	Retransmission Not used with AN/TSQ-97.
	EMER (AN/ARC-115A only)	Automatically switches transmitter to GUARD frequency, disables main receiver, energizes GUARD receiver.

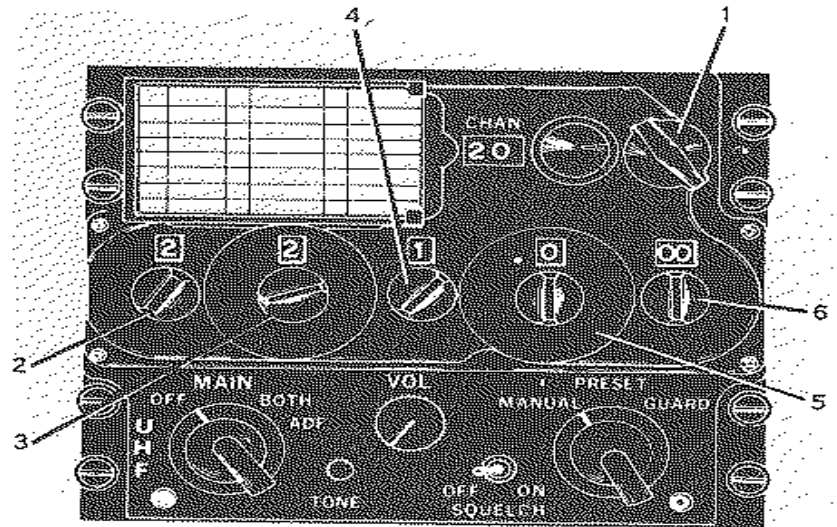


Table 3-4. AN/ARC-11A Front Panel Controls and Indicators (Cont)

Index (see fig. 3-3)	Position	Function
SQUELCH (switch, AN/ARC-115A), screwdriver adjustment (AN/ARC-115)		Adjusts level-at which signals are squelched.
AUDIO control	Variable	Adjusts radio set audio output level. For operation of the AN/TSQ-97, control should be adjusted to position where received audio causes AUDIO indicator to light.



SWITCHING UNIT



ELOSS 015

Figure 3-5. RT-1167/ARC-164(V), Operator Controls and Indicators

Table 3-5. RT-1167/ARC-164(V) Front Panel Controls

Figure. 3-5 Index No.	Item	Position	Function
1	CHAN, Preset channel selector, rotary	1 20	Selects individual preset channels (see para 3-11b). switch
-	MANUAL-PRESET-GUARD rotary switch:	MANUAL	Allows any one of 7000 frequencies to be manually selected by setting the 5 frequency selector switches.
		PRESET	Frequency is selected using the CHAN control to select any one of 20 preset channels.
		GUARD	The main receiver and the transmitter are automatically tuned to the guard channel frequency and the guard channel is disabled.
	Manual frequency selector switches:		
2	Two-position, rotary	2 or 3	Selects 100's digit of frequency in MHz.
3	Ten-position, rotary	0 9	Selects 10's digit of frequency in MHz.
4	Ten-position, rotary	0 9	Selects units digit of frequency in MHz.
5	Ten-position, rotary frequency in MHz.	0 9	Selects tenths digit of
6	Four-position, rotary	00, 25, 50, 75	Selects hundredths and thousandths digits of frequency in MHz.
-	Function selector switch four-position rotary:		Selects operating mode:
		OFF	Removes all operating power from the radio set.
		MAIN	Enables main receiver and transmitter.

Table 3-5. RT-1167/ARC-164(V) Front Panel Controls

Figure. 3-5 Index No.	Item		Position      Function
Function Selector (Cont'd)		BOTH	Enables main receiver, guard receiver and transmitter.
automatic direction			Not used with AN/ ADF Enables
			TSQ-97.      finding or homing system and main receiver.
volume level.			VOL rotary control CW Maximum
			CCW Minimum volume level.
RF carrier with			TONE momentary Pressed Modulates
			pushbutton      1020 Hz tone.
			SQUELCH ON-OFF, two-      -
	- Enables and disables main		position toggle      receiver squelch.
wideband or narrow-	7		BW switch (NB-WB)      -      Selects
			band selectivity of main receiver.
threshold level of	8		SQ-MN control      -      Adjusts
			squelch for main receiver.
level of	9		SQ-GD-control-      Adjusts threshold
			squelch for guard receiver.
	10	PRESET switch	- Stores selected frequency in selected preset channel when pressed.

**Section II. OPERATION UNDER USUAL CONDITIONS**

3-4. Starting and Checkout Procedures. a. Clear and X-Mode, Preset Switches. Prior to energizing the facility for operation, position front panel controls as defined in table 3-6. The radio sets are defined thusly:

- (1) RADIO 1 AN/ARC-114A
- (2) RADIO 2 AN/ARC-115A
- (3) RADIO 3 RT-1167/ARC-164(V)

**Change 2 3-14A**

b. Rear Panel. Check rear panel connections as follows:

(1) *Clear operation.* Check rear panel (radio) connections against cabling diagram (fig. 1-7, FO-1). If using battery BB-451/U, connect cable W701 from battery to POWER IN connector J1. If using vehicular power supply, connect either cable W702 or alternate 50 foot power cable from power source to POWER IN connector J1. Also, if using vehicular power supply, make sure transient suppressor is connected to J2 on rear panel. Proceed to paragraph 3-7.

**NOTE**

A cable diagram decal is affixed to the inside of the rear cover of the AN/ TSQ-97. A cable diagram decal showing TSEC/KY-57 installation is affixed to the inside of the top cover of the MK-2225/ TSQ-97 installation kit.

(2) X-mode operation. For discussion, only radio 1 is referred to. Any radio position (radio 1, 2 or 3) can be made secure by attaching security equipment to the RADIO SECURITY connectors associated with that radio. Attach power cable W701 (BB-451/U), or cable W702 (vehicular), or alternate 50 foot power cable (vehicular), from power source to POWER IN J1. Ensure the transient suppressor is connected to J2 if operating from a vehicular system. Connect secure control cable(s) and secure signal cable(s) to the control monitor and TSEC/KY-38 or TSEC/ KY-57 as follows (for RADIO 1):

(a) Secure control cable P1 to J7 on Control Monitor. Connect P2 to TSEC/KY-38 or connect P2 to adapter cable connected to TSEC/KY-57.

(b) Secure signal cable P1 to J6 on Control Monitor. Connect P2 to TSEC/KY-38 or TSEC/KY-57.

3-5. Facility Operation. Prior to commencing operation, determine the altitude of the site of operation and the wind direction from a reliable source and wind the panel clock.

**NOTE**

Loss of sidetone and distortion may occur in the radios if input voltages are above 30 volts or below 22 volts.

a. Clear Operation. Always check BATTERY meter reading prior to turn on. Optimum operation is obtained when meter indicates a supply voltage of 24 to 30 volts with control monitor POWER OFF/ON set to OFF. Do not use a battery supplying less than 20 volts. For optimum performance, the battery should be changed, if the voltage drops below 22 volts when the transmitter is keyed.

- (1) On rear panel set radio circuit breakers to ON.
- (2) Set POWER ON-OFF switch to ON.
- (3) Set individual radio FUNCTION selector to desired function.

(4) Check that XMT NDDE switch is set to NORM (for clear transmit operation) or to SECURE RADIO 1, 2, or 3 of X-mode transmit operation.

(5) Set XMT-OFF-MON switch for each radio to MON. Radios can now be monitored. Associated AUDIO indicator will light to indicate when audio is being processed from that radio.

Table 3-6. Preoperation Switch Positions

Major Item	Control	Position	Type Communications	
			Clear	X-Mode
Control Monitor, Front Panel:	RADIO 1	Function Selector	OFF	- -
	RADIO	Function Selector	OFF	- -
	RADIO 3	Function Selector	OFF	- -
		POWER ON-OFF	OFF	- -
		XMT MODE	NORM	X
			SECURE RADIO 1	X
			SECURE RADIO 2	X
			SECURE RADIO 3	X
		XMT/OFF/MON	OFF	- -
	Control Monitor, rear panel, CIRCUIT BREAKERS:		RADIO 1 ON/OFF	OFF
		RADIO 2 ON/OFF	OFF	- -
		RADIO 3 ON/OFF	OFF	- -

(6) Connect microphone or headset microphone to HDST/MIC connector. If microphone is used, switch SPKR/HDST HDST switch to SPKR/HDST.

(7) Perform starting and checkout procedures (3-9, 3-10, 3-11) on RADIO 1, 2 and 3. (Required at initial set up checkout only.)

(8) Adjust control monitor VOL control for comfortable listening level.

(9) Note temperature as indicated on thermometer mounted on antenna mast.

(10) Check altimeter indications (see paragraph 3-12).

(11) Assure clock is wound and make a radio time check to verify accuracy.

(12) Press the PUSH-TO-OPERATE switch/indicator and verify WIND DIRECTION indication agrees with previously obtained data. After reading is observed, press again (light off) to conserve the battery until further readings are required.

(13) Check that WIND SPEED (KTS) meter is indicating wind speed (if any) .

**NOTE**

To conserve the battery and preclude detection of operational site at night, keep use of panel illumination minimum.

(14) The LIGHTS switch is springloaded to the center position (off). When panel light is necessary, press switch to MON-ON and hold it as long as required. This also lights the panels of the individual radio sets.

(15) After radio sets have been tuned to required frequencies, set the

applicable radio XMT-OFF-MON switch to XMT and press the PUSH-TO-TALK switch on the input device and speak into the microphone.

**NOTE**

If all three radio sets are used for simultaneous transmission, useful battery life will be appreciably shortened.

b. X-Mode Operation. X-mode operation is essentially the same as outlined for clear operation, except that the XMT MODE switch is set to SECURE RADIO 1, 2 or 3 and the following steps shall be accomplished. Refer to KAO-153A/TSEC (RP-2) for operation instruction for TSEC/KY-38. Specific X-mode operation procedures for TSEC/KY-57 equipment are outlined in Publication TM 11-5810-256-12.

**NOTE**

Equipment operates in normal mode (not ciphered) with XMT MODE switch in SECURE and TSEC/KY-38 CIPHER/PLAIN switch in PLAIN.

Security equipment can be connected to all three radio sets, however only one radio set at a time can be used in X-mode transmit.

(1) First start. For the first daily start:

(a) Key the TSEC/KY-38.

(b) Select SECURE RADIO 1, 2 or 3 (radio must be ON).

(c) Switch TSEC/KY-38 control switch to CIPHER.

(d) Switch TSEC/KY-38 DELAY switch to IN.

(e) Press handset (or microphone) PUSH-TO-TALK button. The results must be three rapid beeps followed by one lower pitched beep from the audio output device. X-mode communications can now commence.

**CAUTION**

If the results of (e) above are not as defined, or are a constant series of beeps during any CIPHER transmission, repeat entire first start procedure. If satisfactory results are still not obtained, change TSEC/KY-38 and/or TSEC battery, or switch to another radio which has security equipment interfaced to it and try again. If first start procedures will not pass, report this to higher level maintenance, and DO NOT USE X-MODE COMMUNICATIONS until fault has been fixed.

(2) Subsequent X-mode transmissions For all X-mode transmissions after first daily start requirements have been met:

(a) On TSEC/KY-38, switch DELAY switch to OUT.

(b) Press headset/microphone (or microphone) PUSH-TO-TALK pushbutton -get 1 beep.

( c) Begin X-mode transmission.

3-6. Operating Procedures for Individual Radio Sets. Refer to paragraphs 3-7, 3-8, and 3-9 for radio set operations.

3-7. Radio Set AN/ARC-114A.

a. Stating and Checkout Procedure.

**NOTE**

Procedures (2) through (6) below constitute a general post installation check of radio set operation. For routing operation, omit (2) through (4) below.

(1) Adjust LAMPS DIM control (on control monitor) for desired panel light.

(2) Rotate the frequency controls to indicate an operating frequency of 30.05 MHz:

(a) Rotate left control until 30 shows up in MEGAHERTZ window to the left of the decimal.

(b) Rotate right control until 05 appears in the MEGAHERTZ window to the right of the decimal.

(3) Press RCVR TEST pushbutton and listen for a tone from the headset or speaker to indicate proper main receiver operation.

(4) Repeat (2) at 39.90 MHz, 47.80 MHz, 56.70 MHz, 65.60 MHz and 73.40 MHz.

(5) Check that there is no noise present in speaker or headset output with the SQUELCH switch set to NOISE.

**NOTE**

Do not use guard channel frequency setting. Transmissions on this channel are limited to emergencies.

(6) Set XMT-OFF-MON switch to XMT. Rotate the frequency controls to the desired operating frequency, or for test purposes to a local VHF-FM station.

(7) Establish communications with the station by keying the transmitter



and speaking into the microphone. Presence of a sidetone indicates proper operation of the transmitter. Adjust the AUDIO control for suitable AUDIO indicator operation (on when receiving).

**NOTE**

Leave the AUDIO control set to this level for operation with the AN/ TSQ-97. Adjust control monitor VOL control for loudness of audio.

b. Transmit/Receive Operation.

(1) With the function selector switch at OFF, set the external dc power circuit breaker to the on position.

(2) Place the function selector switch to the T/R position.

(3) Rotate the megahertz and kilohertz controls for the desired operating frequency.

(4) Establish communication by keying the transmitter and speaking into the microphone.

c. T/R GUARD Operation.

(1) With the function selector switch at OFF, set the external dc power circuit breaker to the on position.

(2) Place the function selector switch to T/R GUARD.

(3) Operate the radio set as described for transmit/receive operation.

**NOTE**

Guard channel reception is not affected by the setting of the megahertz or kilohertz controls. If guard channel signals

are heard while receiving signals on a main receiver communication channel, detune the main receiver by rotating the megahertz control to an open channel. This condition will permit only the priority guard channel signal to be monitored.

d. Stopping Procedure. To terminate operation place the radios function switch to OFF and place the RADIO 1, XMT-OFF-MON switch on the control monitor to OFF.

**NOTE**

To keep the radio on standby, leave the function selector set to T/R and place the XMT-OFF-MON switch to OFF. This allows visual monitoring of reception by viewing AUDIO indicators.

3-8. Radio Set AN/ARC-115(\*).

**CAUTION**

If the facility is being operated from a vehicle power source, the function selector switch on the radio and POWER OFF/ ON on control monitor must be set to OFF prior to starting or stopping the vehicle engine.

a. Starting and Checkout Procedure.

**NOTE**

Perform the following procedures for a post installation check. Procedures in (2) through (6) below constitute a general check of radio

**NOTE (Cont)**

set operation. For normal operation, omit procedures in (3) through (5) below.

(1) Place the function selector switch in the OFF position and the RADIO-2 circuit breaker in the ON position.

(2) Place the function selector switch in the T/R position.

(3) Rotate the megahertz and kilohertz controls for an operating frequency setting of 116.050 MHz in the MEGACYCLES indicator window as follows:

(a) Rotate the megahertz control until the first three digits (116) appear to the left of the decimal in the MEGACYCLE indicator window.

(b) Rotate the kilohertz control until the last three digits (050) appear to the right of the decimal in the MEGACYCLE indicator window.

(4) Press and hold the RCVR TEST pushbutton. Listen for a tone in the headset to indicate proper main receiver operation.

(5) Repeat (4) above at frequency settings of 119.675 MHz, 127.150 MHz, 138.375 MHz, and 145.950 MHz.

**NOTE**

Do not use the guard channel frequency setting. Transmissions on this frequency should only occur under emergency conditions.

(6) Rotate the megahertz and kilohertz controls to the desired frequency setting or, for test purposes, to a local VHF-AM station.

(7) Establish communication with the station by keying the transmitter and speaking into the microphone. Presence of sidetone indicates proper operation of the transmitter. Adjust the AUDIO control for a suitable operation of the AUDIO indicator.

**NOTE**

The AUDIO control will normally remain at this setting during subsequent operating procedures. Do not readjust this control unless necessary.

## b. Transmit/Receive Operation.

(1) Set function selector to OFF. Set RADIO-1 circuit breaker (on control monitor rear panel) to ON.

(2) Set the function selector to T/R.

(3) Rotate the megahertz control (left control) and the kilohertz control (right control) to the desired operating frequency.

(4) Key the microphone and speak into the microphone.

c. T/R Guard Operation. AN/ARC-115 operation is same as b(1) (3) above except the function selector is set to T/R GUARD. On the AN/ARC-115A to automatically set the transmitter to guard frequency, disable the main receiver and energize the guard receiver set to the FUNCTION SELECTOR to EMER.

**NOTE**

Guard channel reception is not affected by the settings of the mega-Hertz or kilohertz control. The guard receiver is fixed-tuned to receive at 121.500 MHz. If guard

**NOTE (Cont)**

channel signals are heard while receiving signals on a main receiver communication channel, detune the main receiver by rotating the megahertz control to an open channel. This will permit only the priority guard channel signal to be monitored.

*d. Retransmission Operation.* The retransmission function of Radio Set AN/ARC-115(\*) cannot be used when installed in AN/TSQ-97.

*e. Stopping Procedure.* To stop the radio set, place the function selector switch in the OFF position.

3-9. Receiver-Transmitter RT-1167/ ARC-164 (V).

**CAUTION**

If the facility is being operated from a vehicle power system, set the function selector to OFF prior to starting or stopping the vehicles engine.

a. Starting and Checkout Procedures.

**NOTE**

These procedures must be accomplished in successive steps exactly as outlined.

(1) Main receiver squelch.

(a) Set function selector to MAIN.

(b) Set MANUAL-PRESET-GUARD selector to MANUAL.

(c) Set SQUELCH switch to ON.

(d) Turn SQ-MN control (under spring-loaded door) counterclockwise until noise is heard. Turn control clockwise just until receiver noise is quiet. Turn control an additional one-eighth turn clockwise.

(2) Guard receiver squelch.

(a) Set function switch to BOTH.

(b) Set MANUAL-PRESET-GUARD control to MANUAL (main receiver SQUELCH must be ON).

(c) Turn SQ-GD control (under spring-loaded door) counterclockwise until noise is heard. Turn control clockwise until noise stops. Continue turning control one-eighth turn clockwise.

b. Setting Preset Frequency Channels. The operating frequency of up to 20 receive/transmit channels can be preset and thereafter can be selected by turning the CHAN selector to the desired channel 1 20. To preset these channels proceed as follows: (1) Set CHAN selector to desired channel. (Start with CHAN 1 if all 20 channels are to be preset.) (2) Set the five frequency select knobs to the desired frequency.

(3) Lift the small spring-loaded door at the upper left corner of the front panel. Press the red PRESET pushbutton. The frequency selected is now established (via internal logic circuitry) as the operating frequency for CHAN 1.

(4) Change the CHAN selector to CHAN 2 and preset this channel to the desired frequency as outlined in (2) and (3) above. Proceed to preset all desired channels the same way. After the desired channels are set, all that is required to transmit and receive at the preset frequencies is to select the applicable channel.

**NOTE**

For future ready reference, fill in the chart on the spring-loaded door as applicable.

c. Transmit/Receive Operation. Proceed as follows for normal voice communications: (1) Set function selector to MAIN.

(2) Set MANUAL-PRESET-GUARD switch to desired method of frequency selection and adjust the associated frequency select controls for the required operating frequency. If PRESET is selected, turn the preset channel control until the desired preset channel is displayed in the window at the upper right of the front panel.

(3) Perform a talk test and adjust the VOL control for a comfortable sidetone level.

(4) Press TONE pushbutton and listen for tone which indicates proper operation of main receiver.

d. T/R Guard Operation. Proceed as follows to monitor the guard channel while maintaining use of the main receiver: (1) Set function selector to BOTH. The main receiver and transmitter operate at the frequency selected and the guard receiver operates at a fixed-tuned frequency of 243 MHz.

(2) Set MANUAL-PRESET-GUARD switch to either MANUAL or PRESET. If PRESET is selected, preset the receiver and transmitter frequencies on the desired channels as outlined in paragraph 3-11b. If MANUAL is selected, use the five frequency select knobs to set the desired receiver and transmitter operating frequency.

**NOTE**

This tuning does not affect the guard receiver frequency which is fixed at 243 MHz.

(3) Key the transmitter and speak into the microphone. Adjust the radio VOL control to cause the AUDIO indicator to light during reception.

e. Stopping Procedure. To terminate operation, set the function selector to OFF.

3-10. Operation of Altimeter in AN/TSQ-97. The altimeter is used to provide the facility operator the barometric pressure indication at the field from which the facility is operating. The barometric pressure displayed in the Kollsman window on the altimeter is then relayed to the pilots for setting aircraft altimeters. Obtain setting as follows:

- a. Determine field elevation from a map or chart.
- b. Adjust the altimeter pointers to the field elevation.
- c. Tap the meter and readjust setting until altitude reading stabilizes.
- d. Read barometric pressure from scale in the Kollsman window.

**NOTE**

As weather conditions change, the altimeter reading will also change. When the field elevation reading changes, b, c, and d above must be repeated.

3-11. Density Altitude Computation. Density altitude is used for computing aircraft performance and is defined as pressure altitude corrected for temperature. To obtain density altitude data for relaying to pilots, proceed as follows:

- a. Adjust the barometric scale in

the pressure (Kollsman) window of the altimeter to indicate 29.92. Tap altimeter until indication stabilizes.

- b. The altitude reading is the pressure altitude.

- c. Determine ambient air temperature from the thermometer mounted on the mast (any equivalent source will do).

- d. Refer to the density altitude computation chart affixed to the front of the AN/TSQ-97 (see figure 1-5). Read the density altitude for the previously obtained pressure altitude and applicable temperature.

**Section III. OPERATION UNDER UNUSUAL CONDITIONS**

3-12. Recognition and Identification of Jamming. Under real or simulated tactical conditions, the radio sets may be jammed by the enemy. Unusual noises or strong interference heard on a radio set may be enemy jamming, signals from a friendly station, noise from a local source, or noise from a defective radio set. A jamming signal may be intended to block a single frequency (spot jamming) or a block or band of frequencies (barrage jamming). Jamming signals may consist of noise, laughter, singing, music, various tones, or any unusual sound or combination of sounds.

3-13. Antijamming. When a radio set is suspected of being jammed, the operator will continue to operate the equipment and immediately notify the officer in charge. To provide maximum

intelligibility of signals that are being jammed, follow normal operational procedures and vary audio level controls as required. If normal procedures do not provide sufficient signal separation for operation, request permission to change to an alternate frequency and alternate call sign.

3-14. High Humidity (Rain) Operation. The facility can be operated in the normal manner during periods of rain if suitable waterproof covering is used to shield the facility from direct drenching.

**WARNING**

Do not operate the facility during electrical storms.

#### Section IV. PREPARATION FOR MOVEMENT

3-15. Battery cold weather limitations. When battery has been cycled under moderate to warm climatic conditions, it should not be used in extreme cold as cells may crack. When relocating to cold environments, new batteries should be used.

##### NOTE

Low temperatures can decrease battery capacity as much as 50% at -30°C. See TM 11-6140-208-15

3-16. Instructions.

*a. Switches.* Set the function selector switches on the radio sets to OFF. On the control monitor, place three XMT-OFF-MON switches to OFF. Position the POWER ON/OFF switch to OFF.

*b. Power Cable.* Disconnect the power cable from the battery or vehicle and the POWER IN connector. Store the cable in the left side storage compartment. The alternate 50 foot power cable is not stored in the storage compartment of the AN/TSQ-97 equipment.

*c. Radio to Choke Cable.* Disconnect W201, W202, W203 coaxial cables from the RF choke. Wrap the cables suitably to be strapped in place for storage. Strap cables in position, using flexible snap strap at the rear of the control monitor.

*d. Security Equipment.* If X-mode communications was employed, disconnect the secure signal cable(s) and secure control cable(s). Store these cables in the front cover. When using TSEC/ KY-57 with installation kit, store cables in top cover of installation kit.

Install connector covers on RADIO SECURITY connectors.

*e. Headset/Microphone.* Disconnect headset/microphone or microphone and store it in right side storage compartment.

*f. Lowered the Antenna Boom.* Use caution. When the antenna boom is lowered, the guy lines no longer support the assembly; have someone help. Hold onto the fiberglass extension and remove the quick-release pin near the top of the metal mast. Lower the mast extension into the mast.

*g. Cable.* W401 and W402. Disconnect the wind sensor cables W401 and W402. Store these cables in the leftside storage compartment.

*h. Cable* W301, W302, and W303. Disconnect antenna cables W301, W302, and W303 from RF choke and antennas. Store these cables in the left-side storage compartment.

*i. RF Choke.* Remove and store the RF choke (see figure 2-1 for storage locations).

*j. Thermometer.* Remove and store the thermometer and bracket.

*k. Antenna Elements.* At the antenna coupler mounting plates, unscrew and remove the (horizontal) antenna elements AS-4034/TSQ-97. Store these items in the front cover.

*l. Whip Antenna.* Unscrew the whip antenna element(s) from the coupler. This antenna element will subsequently be stored in the hollow metal mast.

*m.* Remove and store the antennas and couplers.

n. Remove and store the Wind Detector ML-653/TSQ-97, the vane and standoff.

o. Remove anchor pins at guy line terminations. Store anchor pins in equipment case front cover. Shorten the guy lines and wrap them between storage hooks on the boom.

p. Disconnect the antenna boom from the mast.

q. Install rear cover.

**CAUTION**

Make sure interior of equipment is thoroughly dry and Storage Battery BB-

451/U is removed before installing case covers.

*r. Requires two people.* Lay the facility back onto the rear cover.

*s. Remove* the twist-lock cap from the bottom of the mast. Store the whip-type antenna element(s) in the mast. Replace twist-lock cap.

*t. Install* mast and boom onto the equipment case for carrying handles as shown in figure 1-2.

*u. Install front cover.* The ANI TSQ-97 is now ready for field transportation.

CHAPTER 4

OPERATOR/ORGANIZATIONAL MAINTENANCE INSTRUCTIONS

Section I. INTRODUCTION

4-1. General. To assure dependability and determine operational status, the facility must be inspected periodically as described in Section III. Defects found shall be corrected before they result in serious damage or catastrophic failure. Defects that occur during operation of the facility will be reported to the proper maintenance level for correction immediately upon termination of operation. Essentially, organizational maintenance is limited to replacement of cables, antennas, radios, choke, battery and indicator and illumination lamps. Stop operation immediately if a condition occurs that would damage the equipment or become hazardous to personnel. Record all troubles and the corrective action taken in accordance with the requirements of TM 38-750.

4-2. Tools and Equipment Required. For illustrations of and descriptions of repair parts authorized for organizational maintenance see TM 115895-800-20P. Some commonly used items required for routine maintenance are listed in table 4-1 for reference only. Minimum items required for organizational maintenance are:

- a. Lint-free cleaning cloth
- b. Brush, MIL-G-7241
- c. Tool Kit, Electronic Equipment TK-101/G
- d. Multimeter AN/USM-223

Table 4-1. Tools/Spares/Equipment Commonly Used

	Item Name	Reference Designation	Type	Quantity Required	NSN Use
Lamp	DS1 DS3	MS 25237-387	3	6240-00-763-7744	Panel lights for AUDIO indicators.
Lamp	DS4	MS 25231-313	1	6240-00-155-8714	Lamp for flexible-shaft light.
Lamp	DS5	MS 25237-387	2	6240-00-763-7744	Panel lamps for WIND DIRECTION indicator



Table 4-1. Tools/Spares/Equipment Commonly Used (Cont)

	Item Name	Reference Designation	Type	Quantity Required	NSN Use
Lamp	DS7	MS25237-387	1	6240-00-763-7744	Lamp for PUSH-TO-OPERATE switch/indicator.
Fuse	RADIO 1 FI	-	1	5920-903-1008	Spare fuse for AN/ARC-114A.
Fuse	RADIO 2 F1	-	1	5920-903-1008	Spare fuse for AN/ARC-115( ).
Fuse	RADIO 3 FI	BUSS1 FMO1	1		Spare (5 amp) fuse for RT-1167/ARC-164(V).
Fuse	RADIO 3 F2	BUSS1 FMO1	1		Spare (1A) fuse for RT-1167/ARC-164(V).
Fuse	1AIF1	-	1		Spare 1.5A fuse for DC/AC inverter.
			4-2		

**Section II. PREVENTIVE MAINTENANCE CHECKS AND SERVICES (PMCS)**

4-3. PMCS Requirements. The PMCS requirements for the AN/TSQ-97 are listed in table 4-2. There are certain tests that can be done routinely, before (B) and during (D) operation. Other PMCS are done daily or weekly or when dictated by special circumstances as listed in table 4-2.

a. *Before You Operate.* Always keep in mind the CAUTIONS and WARNINGS. Perform your before (B) PMCS.

b. *While You Operate.* Always keep in mind the CAUTIONS and WARNINGS. Perform your during (D) PMCS.

c. *After You Operate.* Be sure to perform your after (A) PMCS. d. *If Your Equipment Fails to Operate.* Troubleshoot with proper equipment. Report any deficiencies using the proper forms, see TM 38-750.

e. *Routine PMCS Services.* Routine services are a collection of checks and observations performed by the operator at all times. Routine services are not listed in the preventive maintenance checks and services (table 4-2), in order to separate the nonoperational from the operational services.

- (1) Cleaning.
- (2) Dusting.
- (3) Washing.
- (4) Check for cut or frayed cables.
- (5) Check for dented, bent or broken components.
- (6) Check to see that items not in use are properly stowed.
- (7) Check for rusting.
- (8) Check controls for smooth operation.
- (9) Cover unused receptacles.
- (10) Check for loose nuts, bolts, and connectors.
- (11) Check to see that all nameplates are clean and legible.
- (12) Check for completeness of equipment.

4-4. Cleaning. Inspect the exterior of the AN/TSQ-97. The exterior surfaces should be clean and free of dust, dirt, grease, and fungus.

- a. Remove dust and loose dirt with a clean, soft cloth.

**WARNING**

Adequate ventilation should be provided while using TRICHLOROTRIFLUOROETHANE. Prolonged breathing of vapor should be avoided. The solvent should not be used near heat or open flame; the products of decomposition are toxic and irritating. Since TRICHLOROTRIFLUOROETHANE dissolves natural oils, prolonged contact with skin should be avoided. When necessary, use gloves which the solvent cannot penetrate. If the solvent is taken internally, consult a physician immediately.

- b. Remove grease, fungus, and ground-in dirt from the case; use a cloth dampened (not wet) with cleaning compound (NSN 6850-00-105-3084).
- c. Remove dust or dirt from plugs and jacks with a brush.

**CAUTION**

Do not press on glass face of wind direction or wind speed indicators, or indicator faces of any of the radios.

*d.* Clean the front panels and controls knobs and switches; use a soft, clean cloth. If dirt is difficult to remove, dampen the cloth with water; mild soap may be used for more effective cleaning.

4-5. Touchup Painting Instructions. Remove rust and corrosion from metal surfaces by lightly sanding them with fine sandpaper. Brush two thin coats of paint on the bare metal to protect it from further corrosion. Refer to the applicable cleaning and refinishing practices specified in TB 43-0118.

Table 4-2. Organizational Preventive Maintenance Checks and Services

B = BEFORE OPERATION      D = DURING      S = SPECIAL SITUATION\*  
 A = AFTER OPERATION      W = WEEKLY

ITEM NO	INTERVAL					PROCEDURE	EQUIPMENT IS NOT READY/ AVAILABLE IF COLUMN:
	B	A	D	W	S		
1				•		Inspect Storage Battery for corrosion or spilled electrolyte. Make sure battery adapter is firmly connected.	
2		•		•	•	a. Visually check antennas, mast and boom, and supporting structure for damage and stability. b. Check guy lines and anchors; tighten lines if necessary.	
3		•			•	Perform an operability check IAW the operating instructions in par. 3-4 through 3-10 in this technical manual.	The operability check results in a condition whereby the equipment will not be able to complete its intended mission because of equipment malfunction, lack of required equipment or non-application of an URGENT MWO.
4		•			•	Perform PMCS on Radio Set AN/ARC-114 IAW par. 4-5, TM 11-5821-259-20.	Radio Set AN/ARC-114 is NOT READY/AVAILABLE and completion of the intended mission of Air Traffic Control Facility AN/TSQ-97 requires Radio Set AN/ARC-114 to be READY/AVAILABLE.

\*Perform at initial set-up and whenever facility is set up after relocation or when integrity of operation is in doubt.

Table 4-2. Organizational Preventive Maintenance Checks and Services (Cont)

B = BEFORE OPERATION      D = DURING      S = SPECIAL SITUATION\*  
 A = AFTER OPERATION      W = WEEKLY

ITEM NO	INTERVAL					PROCEDURE	EQUIPMENT IS NOT READY/ AVAILABLE IF COLUMN:
	B	A	D	W	S		
5		•			•	Perform PMCS on Radio Set AN/ARC-115 IAW par. 4-7 TM 11-5821-260-20. For Radio Set AN/ARC-115A, use par. 3-7 of TM 11-5821-260-20-1.	Radio Set AN/ARC-115(*) is NOT READY/AVAILABLE and completion of the intended mission of Air Traffic Control Facility AN/TSQ-97 requires Radio Set AN/ARC-115(*) to be READY/AVAILABLE.
6		•			•	Perform PMCS on Radio-Transmitter RT-1167/ARC-164 IAW TM 11-5821-311-12, par. 3-7.	Radio-Transmitter RT-1167/ARC-164 is not READY/AVAILABLE and completion of the intended mission of Air Traffic Control Facility AN/TSQ-97 requires Radio-Transmitter RT-1167/ARC-164 to be READY/AVAILABLE.
7					•	Check that all pertinent publications required for operation and maintenance are current and serviceable.	
8					•	Check DA Pam 310-4 to determine whether new applicable MWO's must be applied immediately. All MWO's must be scheduled.	

\*Perform at initial set-up and whenever facility is set up after relocation or when integrity of operation is in doubt.

### Section III. TROUBLESHOOTING

4-6. General Information. Organizational troubleshooting for the AN/TSQ-97 is based upon inability to perform any of the required operational steps presented in chapter III. If a malfunction occurs, refer to table 4-3 and find the appropriate symptom. Proceed as indicated to analyze the malfunction. If the trouble cause cannot be isolated using these techniques, refer the symptom to higher maintenance for analysis and subsequent repair. If operation of the Radio Frequency Choke MX-9713/TSQ-97 is in doubt, refer to figure FO-3(J) and make continuity tests. Pin-to-pin measurements shall indicate 1 ohm maximum. Pin-to-pin measurements on the same connector shall indicate infinite resistance. The resistance between any two outer conductors of the coaxial connectors shall be less than 1 ohm. Resistance between outer conductor and the center conductor shall be infinite. Replace choke with a new one if any measurements are abnormal.

4-7. Remove/Install Parts or Assemblies.

#### NOTE

Prior to performing any of the following procedures, insure that the associated power circuit breaker on the rear panel is in the off position.

#### a. Indicator Lamps.

(1) *AUDIO lamps.* Unscrew the lens. Grasp the base of the lamp and pull it out of the lens holder. Install new lamp and install lamp/lens assembly.

(2) *Flexible-shaft lamp.* Grasp the adjustable lens (end) portion of

the lamp assembly and pull it off the flexible base. Remove the bayonet base lamp. Install new lamp and replace lamp cover. Adjust red/clear window as necessary.

(3) *PUSH-TO-OPERATE lamp.* Unscrew moisture seal boot. Remove lamp from green lens (pushbutton). Insert new lamp and install lamp and lens into the lamp receptacle. Reinstall weather seal boot.

(4) *Radio lamps.* The panel lamps for the individual radios must be replaced by higher category maintenance.

#### b. Removal of Radio Set AN/ARC-114A.

(1) Disconnect cable connectors from J1 and J2 located at the rear of the radio set.(J3 and J4 are not used in this installation.)

(2) Remove cross-slotted screw that attaches ground strap to radio case. Retain screw.

(3) Loosen six quarter-turn fasteners that attach radio set to mounting panel.

(4) Push radio set out of mounting panel.

#### c. Installation of Radio Set AN/ARC-174A.

(1) Prior to installing the radio, turn the radio panel quarter-turn fasteners to align with the retaining wire of the control monitor. Insert radio set into its mounting panel and tighten six fasteners.

(2) Connect J1 and J2 cable connectors at rear of replacement radio set.

Change 1 4-7

Table 4-3. Troubleshooting Chart

Item No.	Trouble symptom	Probable trouble	Corrective measure
1	Radio 1,2, or 3 AUDIO lamp does not light when transmitting or receiving.	<ol style="list-style-type: none"> <li>1. Defective lamp.</li> <li>2. Defective lamp circuit.</li> <li>3. Radio AUDIO or VOL control not adjusted.</li> </ol>	<ol style="list-style-type: none"> <li>1. Push to test; if still out, replace appropriate lamp (para 4-8).</li> <li>2. Refer to higher category of maintenance.</li> <li>3. Adjust to point where AUDIO indicator lights during reception.</li> </ol>
2	No audio received at one of the radio positions. (Check if same for all positions.)	<ol style="list-style-type: none"> <li>1. Defective radio.</li> <li>2. Defective antenna.</li> <li>3. Poor connection.</li> </ol>	<ol style="list-style-type: none"> <li>1. Press RCVR TEST or TONE button, if no audio is heard, replace radio.</li> <li>2. Check antenna for orientation and completeness.</li> <li>3. Check all antenna and signal cable connections.</li> </ol>
3	Radio 1, 2, or 3	<ol style="list-style-type: none"> <li>1. Blown fuse on inoperative panel.</li> <li>2. Defective antenna.</li> <li>3. Poor connection.</li> </ol> <p style="text-align: center;"><b>Change 1 4-8</b></p>	<ol style="list-style-type: none"> <li>1. Replace fuse. radio set rear</li> <li>2. Check antenna for orientation and completeness.</li> <li>3. Check all antenna and signal cable connections.</li> </ol>

Table 4-3. Troubleshooting Chart (Cont)

Item No.	Trouble symptom	Probable trouble	Corrective measure
4	No transmit side-tone at one of radio positions. (Check if same for all positions.)	<ol style="list-style-type: none"> <li>1. Defective antenna or installation.</li> <li>2. Poor connection.</li> <li>3. Defective radio.</li> </ol>	<ol style="list-style-type: none"> <li>1. Obstruction in front of antenna could cause radio shutdown. Check antenna for damage.</li> <li>2. Check all antenna and signal cable connections.</li> <li>3. Replace radio.</li> </ol>
5	Wind speed or wind direction meter inoperative	<ol style="list-style-type: none"> <li>1. Poor cable connection.</li> <li>2. Defective wind speed or detector circuit.</li> <li>3. Defective ML-653/TSQ-97.</li> </ol>	<ol style="list-style-type: none"> <li>1. Check all cable connections at wind detector, antenna choke and console rear panel.</li> <li>2. Refer to higher level maintenance.</li> <li>3. Replace defective Wind Direction and Speed Detector ML-653/TSQ-97.</li> </ol>



(3) Using cross-recessed head screw, attach ground strap to case of radio.

(4) Perform radio checks indicated in paragraph 3-9.

d. Removal of Radio Set AN/ARC- 115(\*).

(1) Disconnect cable connectors from J1 and J2 located in the rear of the radio set.

(2) Remove cross-slotted screw that attaches ground strap to rear panel of radio.

(3) Loosen six quarter-turn fasteners that attach radio set to mounting panel.

(4) Pull radio set out of mounting panel.

e. Installation of Radio Set AN/ARC-115(\*).

(1) Prior to installation, turn the radio quarter-turn fasteners to align with the retaining wire of the control monitor. Insert radio set into its mounting panel and tighten six fasteners.

(2) Connect J1 and J2 cable connectors to rear of the replacement radio set.

(3) Using cross-recessed head screw, connect ground strap to radio back panel.  
it.

(4) Perform radio set checks indicated in paragraph 3-10.

f. Removal of Receiver-Transmitter RT-1167/ARC-164(V).

(1) Disconnect cable connectors from J1 and J2 on the rear panel.

(2) Loosen eight quarter-turn fasteners that attach radio set to mounting panel.

(3) Pull radio set out of mounting panel.

g. Installing Receiver-Transmitter RT-116/ARC-164(V).

(1) Prior to installation, turn the radio quarter-turn fasteners to align with the retaining wire of the control monitor. Insert radio set into its mounting panel and tighten eight quarter-turn fasteners.

(2) Connect J1 and J2 cable connectors to rear of replacement radio.

(3) Perform radio set checks indicated in paragraph 3-11.

h. Replacement of Transient Suppressor.

**NOTE**

The function of the transient suppressor is to damp heavy current surges that may be produced by a vehicular power supply. When a battery is used, the transient suppressor has no function.

(1) When lamp on transient suppressor is lighted, turn POWER OFF, unscrew suppressor, remove and discard

(2) Screw replacement transient suppressor onto connector. Under the same conditions, the lamp should not light.

## APPENDIX A

## REFERENCES

---

DA Pam 310-1	Consolidated Index of Army Publications and Blank Forms.
DA Pam 738-750	The Army Maintenance Management System (TAMMS).
SB 11-573	Painting and Preservation Supplies Available for Field Use for Electronics Command Equipment.
SB 38-100	Preservation, Packaging, Packing and Marking Materials, Supplies, and Equipment Used by the Army.
SB 700-20	Army Adopted/Other Items Selected for Authorization/List of Reportable Items (Available in 48x Microfiche only).
TB SIG 291	Safety Measures to be Observed When Installing and Using Whip Antennas, Field Type Masts, Towers, Antennas, and Metal Poles That are Used With Communication, Radar, and Direction Finder Equipment.
TB 43-0118	Field Instructions for Painting and Preserving Electronics Command Equipment, Including Camouflage Pattern Painting of Electrical Equipment Shelters.
TMII-5810-25612	Operator's and Organizational Maintenance Manual, Communications Security Equipment TSEC/KY-57
TM 11-5821-259-20	Organizational Maintenance Manual: Radio Sets, AN/ARC-114 and AN/ARC-114A, Network, Impedance Matching, CU-1794/ARC-114; Network, Impedance Matching, Quadrature Hybrid, CU-1796/ARC-114.
TM 11-5821-260-20	Organizational Maintenance Manual: Radio Set ANIARC-115.
TM 11-5821-311-12	Operator's and Organizational Maintenance Manual, Receiver-Transmitter, Radio RT-1167/ARC-164(V) (NSN 5821-00-138-7990).
TM 11-6130-351-14	Operator's, Organizational, Direct Support and General Support Maintenance Manual Including Repair Parts and Special Tools Lists (Including Depot Maintenance Repair Parts and Special Tools) for Battery Charger PP-6241/U.
TM 11-6140-208-15	Organizational, Direct Support, General Support, and Depot Maintenance Manual for Storage Battery BB-451/U (NSN 6140-00-889-1027).
TM 11-6625-446-15	Operator's Organizational, DS, GS, and Depot Maintenance Manual: Wattmeter AN/URM-120 (NSN 6625-00-790-2746).
KAO-153A/TSEC (RP-2) (Confidential)	Operating Instructions for TSEC/KY-8128/38.
TM 750-244-2	Procedures for Destruction of Electronics Materiel to Prevent Enemy Use (Electronics Command).

## APPENDIX B

## COMPONENTS OF END ITEM LIST

## Section I. INTRODUCTION

B-1. Scope. This appendix lists integral components of and basic issue items for the Air Traffic Control Facility to help you inventory items required for safe and efficient operation.

B-2. General. This Components of End Item List is divided into the following sections:

*a. Section II.* Integral Components, of the End Item. These items, when assembled, comprise the Air Traffic Control Facility and must accompany it whenever it is transferred or turned in. Illustration FO-2 will help you identify these items.

*b. Section III.* Basic Issue Item Not applicable

B-3. Explanation of Columns.

*a. Illustration.* This column is divided as follows:

(1) *Figure number.* Indicates the figure number of the illustration on which the item is shown.

(2) *Item number.* The number used to identify item called out in the illustration.

*b. National Stock Number.* Indicates the National stock number assigned to the item and which will

be used for requisitioning.

*c. Part Number.* Indicates the primary number used by the manufacturer, which controls the design and characteristics of the item by means of its engineering drawings, specifications, standards, and inspection requirements to identify an item or range of items.

*d. Description.* Indicates the Federal item name and, if required, a minimum description to identify the item.

*e. Location.* The physical location of each item listed is given in this column. The lists are designed to inventory all items in one area of the major item before moving on to an adjacent area.

*f. Usable On Code.* Not applicable.

*g. Quantity Required (Qty Reqd).* This column lists the quantity of each item required for a complete major item.

*h. Quantity.* This column is left blank for use during an inventory. Under the Rcv'd column, list the quantity you actually receive on your major item. The Date columns are for your use when you inventory the major item at a later date; such as for shipment to another site.

Section II. INTEGRAL COMPONENTS OF THE END ITEM

(1) Illustration		(2) National Stock Number	(3) Part No.	(4) Description	(5) Location	(6) Usable On Code	(7) Qty Reqd	(8) Quantity			
(a) Figure No.	(b) Item No.							Rev'd	Date	Date	Date
FO-2 1-1		5895-00- 1357-8548	DL-SC-B- 706000	Air Traffic Control Facil- ity AN/TSQ- 97	-		1				
1-2, FO-2	- 1		DL-SC-B- 706362	Case Assembly	-		1				
FO-2	2		DL-SC-B- 706165	Control Monitor C-9921/TSQ-97	-		1				
3-2 FO-2	2 3		SC-C- 706243	Transient Sup- pressor	Rear panel. J2		1				
FO-2	4		M-80/U	Microphone	Connect to front panel J13		1				
FO-2	5		SC-C- 706299	Headset/ Microphone H-337/TSQ- 97	Connects to front panel J13		1				
FO-2	6	SC-C- 706040	Guy Lines Assembly sembly	Part of Boom As-		2					
<b>Change 1 B-2</b>											

Section II. INTEGRAL COMPONENTS OF THE END ITEM (Cont)

(1) Illustration		(2) National Stock Number	(3) Part No.	(4) Description	(5) Location	(6) Usable On Code	(7) Qty Reqd	(8) Quantity			
(a) Figure No.	(b) Item No.							Rev'd	Date	Date	Date
FO-2	7		MIL-P-501 TYPE II	Anchor Pins	Front Cover		4				
2-1, FO-2	8		DL-SC-B- 706256	Vehicular Power Cable W702	Rear Stor- age Com- partment		1				
2-1, FO-2	9		MX-4430( ) PRC-47	Battery Ter- minal Adapter	Battery Storage Comp.		1				
FO-2	10		DL-SC-B- 706253	Primary W701 (Battery) Power Cable	Rear Stor- age Com- partment		1				
FO-2	11		DL-SC-B- 706006	Mast Assembly	(Carrying Handle)		1				
FO-2	12		DL-SC-B- 706115	Wind Det Cable W401 (J12 to Choke)	Rear Stor- age Comp.		1				
FO-2	13		DL-SC-B- 706264	Radio Antenna Cable W203	Rear Stor- age Comp.		1				
FO-2	14		DL-SC-B- 706261	Radio Antenna Cable W202	Rear Stor- age Comp.		1				
2-1, FO-2	6 15		MS28028-1	Thermometer Rubber Storage	Rear Foam		1				
2-1, FO-2	1 16		DL-SC-B- 706057	Thermometer Bracket Storage	Rear Foam Rubber		1				
FO-2	17		DL-SC-B- 706113	Radio Antenna Cable W201	Rear Stor- age Com- partment		1				
FO-2	18		DL-SC-B- 706044	Choke, RF MX-9713/ TSQ-97	Rear Foam Rubber Storage		1				

Section II. INTEGRAL COMPONENTS OF THE END ITEM (Cont)

(1) Illustration		(2) National Stock Number	(3) Part No.	(4) Description	(5) Location	(6) Usable On Code	(7) Qty Reqd	(8) Quantity			
(a) Figure No.	(b) Item No.							Rev'd	Date	Date	Date
FO-2	19	5821-00-082-3991	DL-SC-B-706037	Boom Assembly	(Carrying handle)		1				
FO-2	20		DL-SC-B-706100	Antenna Element AS-4034/TSQ-97	Front Cover		12				
1-4, 2-1, FO-2	1 7 21		DL-SC-B-706027	Coupler Assembly (for whip type antennas)	Rear Foam Rubber Storage		2				
1-4, FO-2	22		AS-1703( )/AR	Antenna AS-1703()/ARC-54	Stored in carrying handle		2				
FO-2	23		DL-SC-B-706109	Antenna to Choke Cable W301	Rear Storage Compartment		1				
FO-2	24		DL-SC-B-706321	Antenna to Choke Cable W303	Rear Storage Compartment		1				
FO-2	25		DL-SC-B-706112	Cable, Wind Detector to Choke W402	Rear Storage Compartment		1				
1-6, 2-1, FO-2	- 8 26		DL-SC-B-706061	Detector, Wind Direction and Speed ML-653/TSQ-97	Rear Foam Rubber Storage		1				
1-6, FO-2	- 27		SC-C-706064	Rudder (vane) Assembly for Wind Detector	Rear Foam Rubber Storage (P/O item 26)		1				
FO-2	28		SC-C-706031	Standoff	Rear Foam Rubber Storage		1				

Section II. INTEGRAL COMPONENTS OF THE END ITEM (Cont)

(1) Illustration		(2) National Stock Number	(3) Part No.	(4) Description	(5) Location	(6) Usable On Code	(7) Qty Reqd	(8) Quantity			
(a) Figure No.	(b) Item No.							Rev'd	Date	Date	Date
FO-2	29	5821-00-165-2970	DL-SC-B-706320	Antenna to Choke Cable W302	Rear Storage Compartment		1				
1-5, FO-2	- 30		DL-SC-B-706059	Antenna Assembly	Rear Foam Rubber Storage		1				
1-3	-		AN/ARC-114A	Radio Set AN/ARC-114A	Control Monitor		1				
1-3	-		AN/ARC-115A	Radio Set AN/ARC-115A	Control Monitor		1				
1-3	-		RT-1167/ARC-164(V)	Receiver-Transmitter RT-1167/ARC-164(V)	Control Monitor		1				
1-7, 2-2	-		DL-SC-B-706259	Cable Assembly, Secure Signal	Front Cover		3				
1-7, 2-2	-		DL-SC-B-706262	Cable Assembly, Secure Control	Front Cover		3				
1-7, 2-2	-		DL-SC-B-706265	Cable Assembly, Radio Control	Front Cover		3				

## APPENDIX C

MAINTENANCE ALLOCATION

---

## Section I. INTRODUCTION

C-1. General. This appendix provides a summary of the maintenance operations for AN/TSQ-97. It authorizes categories of maintenance for specific maintenance functions on repairable items and components and the tools and equipment required to perform each function. This appendix may be used as an aid in planning maintenance operations.

C-2. Maintenance Functions. Maintenance functions will be limited to and defined as follows:

*a. Inspect.* To determine the serviceability of an item by comparing its physical, mechanical, and/or electrical characteristics with established standards through examination.

*b. Test.* To verify serviceability and to detect incipient failure by measuring the mechanical or electrical characteristics of an item and comparing those characteristics with prescribed standards.

*c. Service.* Operations required periodically to keep an item in proper operating condition, i.e., to clean (decontaminate), to preserve, to drain, to paint, or to replenish fuel, lubricants, hydraulic fluids, or compressed air supplies.

*d. Adjust.* To maintain, within prescribed limits, by bringing into proper or exact position, or by setting the operating characteristics to the specified parameters.

*e. Align.* To adjust specified variable elements of an item to bring about optimum or desired performance.

*f. Calibrate.* To determine and cause corrections to be made or to be adjusted on instruments or test measuring and diagnostic equipments used in precision measurement. Consists of comparisons of two instruments, one of which is a certified standard of known accuracy, to detect and adjust any discrepancy in the accuracy of the instrument being compared.

*g. Install.* The act of emplacing, seating, or fixing into position an item, part, module (component or assembly) in a manner to allow the proper functioning of the equipment or system.

*h. Replace.* The act of substituting a serviceable like type part, subassembly, or module (component or assembly) for an unserviceable counterpart.

*i. Rebuild.* The application of maintenance services (inspect, test, service, adjust, align, calibrate, replace) or other maintenance actions (welding, grinding, riveting, straightening, facing, remachining, or resurfacing) to restore serviceability to an item by correcting specific damage, fault, malfunction, or failure in a part, subassembly, module (component or assembly), end item, or system.



j. Overhaul. That maintenance effort (service/action) necessary to restore an item to a completely serviceable/ operational condition as prescribed by maintenance standards (i.e., DMWR) in appropriate technical publications. Overhaul is normally the highest degree of maintenance performed by the Army. Overhaul does not normally return an item to like new condition.

k. Rebuild. Consists of those services/actions necessary for the restoration of unserviceable equipment to a like new condition in accordance with original manufacturing standards. Rebuild is the highest degree of material maintenance applied to Army equipment. The rebuild operation includes the act of returning to zero those age measurements (hours, miles, etc.) considered in classifying Army equipments/components.

C-3. Column Entries.

a. *Column 1, Group Number.* Column 1 lists group numbers, the purpose of which is to identify components, assemblies, subassemblies, and modules with the next higher assembly.

b. *Column 2, Component/Assembly.* Column 2 contains the noun names of components, assemblies, subassemblies, and modules for which maintenance is authorized.

c. *Column 3, Maintenance Functions.* Column 3 lists the functions to be performed on the item listed in column 2. When items are listed without maintenance functions, it is solely for purpose of having the group numbers in the MAC and RPSTL coincide.

d. *Column 4, Maintenance Category.* Column 4 specifies, by the listing of a work time figure in the appropriate subcolumn(s), the lowest level of maintenance authorized to perform the function listed in column 3. The figure represents the active time required to perform that maintenance function at the indicated category of

maintenance. If the number or complexity of the tasks within the listed maintenance function vary at different maintenance categories, appropriate work time figures will be shown for each category. The number of task- hours specified by the work time figure represents the average time required to restore an item (assembly, subassembly, component, module, end item or system) to a serviceable condition under typical field operating conditions. This time includes preparation time, troubleshooting time, and quality assurance/quality control time in addition to the time required to perform the specific tasks identified for the maintenance functions authorized in the maintenance allocation chart. Subcolumns of column 4 are as follows:

C - Operator/Crew

O- Organizational

F - Direct Support

H - General Support

D - Depot

e. *Column 5, Tool and Equipment.* Column 5 specifies by code those common tool sets (not individual tools) and special tools, test, and support equipment required to perform the designated function.

f. *Column 6, Remarks.* Column 6 contains an alphabetic code which leads to the remark in Section IV, Remarks, which is pertinent to the item opposite the particular code.

C-4. Tool and Test Equipment Requirements (Section III).

a. *Tool or Test Equipment Reference Code.*

The numbers in this column coincide with the numbers used in the tools and equipment column of the MAC. The numbers indicate the applicable tool or test equipment for the maintenance functions.

*b. Maintenance Category.* The codes in this column indicate the maintenance category allocated the tool or test equipment.

*c. Nomenclature.* This column lists the noun name and nomenclature of the tools and test equipment required to perform the maintenance functions.

*d. National/NATO Stock Number.*  
This column lists the National/NATO stock number of the specific tool or test equipment.

a. Tool Number. This column lists the manufacturer's part number of the tool followed by the

Federal Supply Code for manufacturers (5-digit) in parentheses.

C-5. Remark (Section IV).

a. Reference Code. This code refers to the appropriate item in Section II, column 6.

b. Remarks. This column provides the required explanatory information necessary to clarify items appearing in Section II.

**Change 1 C-3**

**Section II. MAINTENANCE ALLOCATION CHART  
FOR  
AIR TRAFFIC CONTIROL FACILITY AN/TSQ-97**

(1) GROUP NUMBER	(2) COMPONENT ASSEMBLY	(3) MAINTENANCE FUNCTION	(4) MAINTENANCE CATEGORY					(5) TOOLS AND EQUIPMENT	(6) REMARKS
			C	O	F	H	D		
00	Air Traffic Control Facility AN/TSQ- 97 (SC-D-706000)	Inspect		0.1					A
		Test		0.1					B
		Test			0.3				B
		Test				0.3			
		Service		0.2					
		Adjust		0.1					C
		Install		0.3					
		Repair		1.0				2,11	D
		Repair			1.0			3,6,10	E
		Repair					2.0	3,4,5,7, 10	
01	Radio Set AN/ARC- 114( )	Replace		0.2			11	F	
02	Radio Set AN/ARC- 115( )	Replace		0.2			11	G	
03	Radio Receiver- Transmitter RT- 1167/ARC-164(V)	Replace		0.2			11	H	
04	Air Traffic Control Facility (SC-D- 706003)	Inspect		0.1					A
		Test			0.3				B
		Test				0.3			B
		Repair			1.0			3,6,10	E
		Repair				2.0		3,4,5,7, 10	
0402	Case Assembly (SC- D-706362)	Inspect			0.2				A
		Repair			0.3			3,10	I
		Repair				1.0		3,10	
	Control Monitor (SC-D-706165)	Inspect			0.1				A
		Test			0.5			4,6,7	
		Test				0.5		3,4,5,7,10	
		Replace			0.3			3	
		Repair		0.2				2,11	S
Repair			0.5			3,45,7,10	J		
Repair				1.0		3,4,5,7,10			

**Section II. MAINTENANCE ALLOCATION CHART  
FOR  
AIR TRAFFIC CONTIROL FACILITY AN/TSQ-97 (Cont)**

(1) GROUP NUMBER	(2) COMPONENT ASSEMBLY	(3) MAINTENANCE FUNCTION	(4) MAINTENANCE CATEGORY					(5) TOOLS AND EQUIPMENT	(6) REMARKS
			C	O	F	H	D		
040201	Front Panel Assem- bly (SC-D-706213)	Inspect Test Test Repair Repair Repair Replace			0.1 0.2			4,6,7 3,4,6,7	A
			0.2			0.2		2,11 2,3,10	S K
04020101	Wind Direction In- dicator	Replace		6.0	6.0			2,3,10	L
04020102	Altimeter AAO-8/A	Replace		0.5				3	M
40202	Rear Panel Assem- bly (SC-D-706223)	Test Test Repair Repair Repair			0.2			4,6,7 3,4,6,7	
			0.2			0.2		2,11 3,10	S N
04020201	Board (SC-C-706233)	Interface Circuit Replace Repair	Test			2.0		2,3,10	B
					1.0			3,10	
04020202	Relay Board Assem- bly (SC-C-705050)	Test Replace Repair			0.1 0.1		2 10	2,3,10	
040203	Control Circuit Board Assembly (SC- C-706228)	Test Test Adjust Replace Repair			1.0			2,6,8,10	O
					1.0			2	
					0.1		7	1-5,710	
					0.1			3,10	
040204	Microphone Ampli- fier Printed Cir- cuit Board Assembly (SC-C-706200)	Test Test Adjust Replace Repair			0.1			2,3,8,9,10	O
					0.1			1,2,5 1-5,710	
					0.1			7	
						1.5L		3,10 1-4,8-10	O
		<b>Change 2 C-5</b>							

**Section II. MAINTENANCE ALLOCATION CHART  
FOR  
AIR TRAFFIC CONTIROL FACILITY AN/TSQ-97 (Cont)**

(1) GROUP NUMBER	(2) COMPONENT ASSEMBLY	(3) MAINTENANCE FUNCTION	(4) MAINTENANCE CATEGORY					(5) TOOLS AND EQUIPMENT	(6) REMARKS
			C	O	F	H	D		
040205	Headset Amplifier printed Circuit Board Assembly (SC- B-706195)	Test Test Replace Repair			0.1  0.1	0.2  1.5L		1,2,7 1-5,7-10 3,10 1-4,8-10	
040206	Lamp Indicator Printed Circuit Board Assembly (DL-SB-706205)	Test Test Replace Repair			0.1  0.1	0.2  1.0L		1,2,7 1-5,7-10 3,10 1-4,8-10	O
040207	Card Enclosure As- sembly (SC-C- 706186)	Inspect Repair			0.1 0.3			2,3,4,10	A
04020701	Mother Printed Cir- cuit Board Assembly	Test Repair			0.5 2.5			2 2,3,10	
0403	Mast Assembly (SC-D-706007)	Replace Repair		0.2 0.3				11 2,11	
0404	Coupler Assembly (Antenna Coupler CU942B/ARC or An- tenna Coupler CU- 2206) (SC-D-706027)	Repair		0.5				11	P,Q
0405	UHF/VHF Antenna As- sembly (AT108/ARC) (SC-D-706059)	Test Replace Repair		0.1 0.1		0.5		2 11 2,3	
0406	Detector, Wind Dir- ection and Speed ML- 653/TSQ-97 (SC-D- 706061)	Test Replace Repair		0.1 0.5		2.0		2,3 2,3,5	B
0407	Headset/Microphone H-337/U	Replace Repair		0.1	0.2			2,3	O

**Section II. MAINTENANCE ALLOCATION CHART  
FOR  
AIR TRAFFIC CONTIROL FACILITY AN/TSQ-97 (Cont)**

(1) GROUP NUMBER	(2) COMPONENT ASSEMBLY	(3) MAINTENANCE FUNCTION	(4) MAINTENANCE CATEGORY					(5) TOOLS AND EQUIPMENT	(6) REMARKS
			C	O	F	H	D		
0408	Antenna AS-1703/ARC	Replace		0.1				3	P,Q
0409	Adapter, Battery (MX-4430/PRC-47)	Replace		0.1					R
0410	Cable Assy, Secure Signal (SC-D-706259;	Repair			1.0			2,3	
0411	Cable Assy, Secure Control (SC-D-706252)	Repair			1.0			2,3	
0412	Cable Assy, Radio Control (SC-D-706265)	Repair			1.0			2,3	
0413	Cable Assy, W-401 (SC-D-706115)	Repair			1.0			2,3	
0414	Cable Assy, W-402 (SC-D-706112)	Repair			1.0			2,3	
0415	Cable Assy, W-701 (SC-D-706253)	Repair			1.0			2,3	
0416	Cable Assy, W-702 (SC-D-706256)	Repair			1.0			2,3	
0417	Cable Assy, W-201 (SC-D-706113)	Repair			1.0			2,3	
0418	Cable Assy, W-202 (SC-D-706261)	Repair			1.0			2,3	
0419	Cable Assy, W-203 (SC-D-706264)	Repair			1.0			2,3	
0420	Cable Assy, W-301 (SC-D- 706109)	Repair			1.0			2,3	

**Section II. MAINTENANCE ALLOCATION CHART  
FOR  
AIR TRAFFIC CONTIROL FACILITY AN/TSQ-97 (Cont)**

(1) GROUP NUMBER	(2) COMPONENT ASSEMBLY	(3) MAINTENANCE FUNCTION	(4) MAINTENANCE CATEGORY					(5) TOOLS AND EQUIPMENT	(6) REMARKS
			C	O	F	H	D		
0421	Cable Assy, W-302 (SC-D-706320)	Repair			1.0			2,3	
0422	Cable Assy, W-303 (SC-D-706321)	Repair			1.0			2,3	
0423	Cable Assy,Power (SC-D-706257)	Repair			1.0			2,3	
05	Installation Kit, Electronic Equip- ment (SC-D-706250)	Inspect		0.2				3	A
		Test		0.1				2,3	
		Test			0.3			2,3,7	
		Repair			1.0			3,10	
0501	Case Assembly (SC- D-706251)	Inspect			0.1				
		Repair			0.2			3	
0502	Panel, Power Distri- bution (SC-D-706252)	Test			0.5			2,3	
		Repair			0.5			3,4	
0503	Cable Assy (SC-D-706253)	Repair			1.0			2,3	
0504	Cable Assy (SC-D- 706300)	Repair			1.0			2,3	
0505	Cable Assy (SC-D-706287)	Repair			1.0			2,3	
06	TSEC/KY-57	Replace		0.2				11	T

**Section III. TOOL AND TEST EQUIPMENT REQUIREMENTS  
FOR  
AIR TRAFFIC CONTROL FACILITY AN/TSQ-97**

TOOL OR TEST EQUIPMENT REF CODE	MAINTENANCE CATEGORY	NOMENCLATURE	NATIONAL/NATO STOCK NUMBER	TOOL NUMBER
1	F,H,D	Audio Oscillator TS-421/U	6625-00-669-0228	
2	O,F,H,D	Multimeter AN/USM-223	6625-00-999-7465	
3	F,H,D	Tool Kit, Electronic Equipment TK-100/G	5180-00-605-0079	
4	F,H	Multimeter ME-30	6625-00-643-1670	
5	F,H	Oscilloscope AN/USM-281	6625-00-053-3112	
6	F,H	Wattmeter, An/URM-120	6625-00-649-5070	
7	F,H	Voltmeter, Digital AN/GSM-64	6625-00-870-0264	
8	H,D	Test Set, Semiconductor Device TS-1836/U	6625-00-893-2628	
9	H,D	Repair Kit, Printed Circuit Board MK-772/U	5999-00-757-7042	
10	F,H,D	Tool Kit, Electronic Equipment TK-105/G	5180-00-610-8177	
11	0	Tool Kit, Electronic Equipment TK-101/G	5180-00-064-5178	
		The following list reflects Test Equipment Items from the ACC Preferred Items List (PIL) identified with the same tool or Test Equipment Code as used for the equivalent standard CECOM (B16) Army Adopted Items:		
1,4	F,H,L,D	Telephone Test Set, AN/USM-423	6625-00-015-6563	
2,7	O,F,H,I,D	Voltmeter, Digital MES18/U	6625-01-031-0708	
<b>Change 2 C-9</b>				



**Section III. TOOL AND TEST EQUIPMENT REQUIREMENTS  
FOR  
AIR TRAFFIC CONTROL FACILITY AN/TSQ-97**

TOOL OR TEST EQUIPMENT REF CODE	MAINTENANCE CATEGORY	NOMENCLATURE	NATIONAL/NATO STOCK NUMBER	TOOL NUMBER
3	F,H,L,D	Tool Kit, Electronic Equipment TK-100/G	5180-00-605-0079	
5	F,H,L	Oscilloscope AN/USM-281C with 2 each AM-6565/U and 1 each TE-208S/U	6625-00-106-9622	
6	F,H	Wattmeter, AN/URM-120	6628-00-649-5070	
8	H,L,D	Test Set, Semiconductor TS-1836D	6625-00-138-7320	
9	H,L,D	Repair Center Electronic PACE Model PRC-350-C	4940-01-031-4541	
10	F,H,L,D	Tool Kit, Electronic Equipment TK-10S/G	5180-00-610-8177	
11	O	Tool Kit, Electronic Equipment TK-101/G	5180-00-064-5178	
<b>Change 2 C-10</b>				

Section IV. REMARKS

REFERENCE CODE	REMARKS
A	Visual. Exterior only.
B	Operational.
C	Operational. Receiver Squelch, Light Dimmers, Audio Volume.
D	Repair by placing knobs, lamps, fuses, hardware, battery adapter, wind direction detector, coupler assembly, antenna assembly and throwaway, boom, choke assembly, lanyards, thermometer, dynamic microphone and hardware.
E	Repair by replacing control monitor, case hardware, shock mounts, wiring harnesses and gaskets. Repair all items except wire harness and circuit boards.
F	TM11-5821-259-20 for AN/ARC-114(). See MAC repair.
G	TM11-5821-260-20 for AN/ARC-115(). See MAC repair.
H	TM11-5821-311-12 for RT-1167/ARC-164( ). See MAC repair.
I	Repair by replacing throwaway lanyards, pressure relief valve, shock mounts, gasket assemblies and case hardware.
J	Repair by replacing fuses, receptacles, gaskets, fuseholders, lamps, relay board assembly, circuit card assemblies, hinges and throwaway power supply, speaker, terminal board and hardware.
K	Repair by replacing azimuth indicator, pressure altimeter, and throwaway receptacles, RF filter, gaskets, lights, audio transformer, voltmeter, ammeter, aircraft clock, circuit breaker, switches, semiconductor device and knobs.
L	TM11-5826-204-35 for ID-637/ARN. See MAC for repair.
M	TM55-6610-229-40 for altimeter AAU-8/A. See MAC for repair.
N	Repair by replacing circuit board assemblies and throwaway gaskets, springs, circuit breakers and hardware.
O	For equipments operated and maintained by US Army Communications Command Circuit card assemblies designed "L" will be repaired by Specialized Repair Activities as designated below:

Section IV. REMARKS

REFERENCE CODE	REMARKS
	<p>KOREA. Return to AMSF USA CC-J APO San Francisco 96331                      EUROPE. Return to 5th Signal Command AMSF, Manheim, Germany.                      CONUS. Return to USACC Agency AMF, Ft Rucker, Alabama.</p>
P	<p>TM11-5821-244-12, Antenna Coupler CU-942B/ARC; Antenna AS-1703/ARC.                      CU-2206 is not repairable.</p>
Q	<p>Repair by replacing defective major components.</p>
R	<p>TM11-5820-509-35, Battery terminal adapter MX-4430/47.</p>
S	<p>Repair by replacing fuses, lamps and knobs.</p>
T	<p>TM11-5810-256-12 for TSEC KY57. See MAC for repair.</p>
<p><b>Change 2 C-12</b></p>	

## APPENDIX D

## EXPENDABLE SUPPLIES AND MATERIALS LIST

## Section I. INTRODUCTION

D-1. Scope. This appendix lists expendable supplies and materials you will need to operate and maintain the Air Traffic Control Facility. These items are authorized to you by CTA50- 970, Expendable Items (except Medical, Class V, Repair Parts, and Heraldic Items).

D-2. Explanation of Columns.

*a. Column 1 - Item Number.* This number is assigned to the entry in the listing and is referenced in the narrative instructions to identify the material (e.g., "Use cleaning compound, item 5, App. D").

*b. Column 2 - Level.* This column identifies the lowest level of maintenance that requires the listed item. (enter as applicable)

C - Operator/Crew

0 - Organizational Maintenance

F - Direct Support Maintenance

H - General Support Maintenance

*c. Column 3 - National Stock Number.* This is the National stock number assigned to the item; use it to request or requisition the item.

*d. Column 4 - Description.* Indicates the Federal item name and, if required, a description to identify the item. The last line for each item indicates the part number followed by the Federal Supply Code for Manufacturer (FSCM) in parentheses, if applicable.

*e. Column 5 - Unit of Measure (U/M).* Indicates the measure used in performing the actual maintenance function. This measure is expressed by a two-character alphabetical abbreviation (e.g., ea. in. pr.) If the unit of measure differs from the unit of issue, requisition the lowest unit of issue that will satisfy your requirements.

Change 1 D-1

## Section II. TABULAR LISTING

(1)	(2)	(3)	(4)	(5)
<u>ITEM NUMBER</u>	<u>LEVEL</u>	<u>NATIONAL STOCK NUMBER</u>	<u>DESCRIPTION</u>	<u>U/M</u>
1	F		Adhesive, MIL-A-46146 Type I, Gray	AR
2	A11		Brush, MIL-G-7241	EA
3	A11	6850-00-105-3085	Trichlorotrifluoroethane	16 oz

**APPENDIX E****ADDITIONAL AUTHORIZATION LIST**

---

**Section I. INTRODUCTION**

E-1. Scope. This appendix lists additional items you are authorized for the support of the AN/TSQ-97.

E-2. General. This list identifies items that do not have to accompany the AN/TSQ-97 and that do not have to be turned in with it. These items are all authorized to you by CTA,

MTOE, TDA, or JTA.

E-3. Explanation of Listing. National stock numbers, descriptions, and quantities are provided to help you identify and request the additional items you require to support this equipment.

**Section II.****ADDITIONAL AUTHORIZATION LIST**

NATIONAL STOCK NUMBER	PART NUMBER AND FSCM	DESCRIPTION	USABLE ON CODE	U/M
6140-00-889-1027	MIL-B-82117-2 81349	Battery, Storage BB-451/U	NA	EA
5895-01-147-5015	SC-D-706250 80063	Kit, Installation MK222S/TSQ-97	NA	EA
5995-01-147-8634	SC-D-706257 80063	Assembly, Power Cable	NA	EA

**Change 2 E-2**

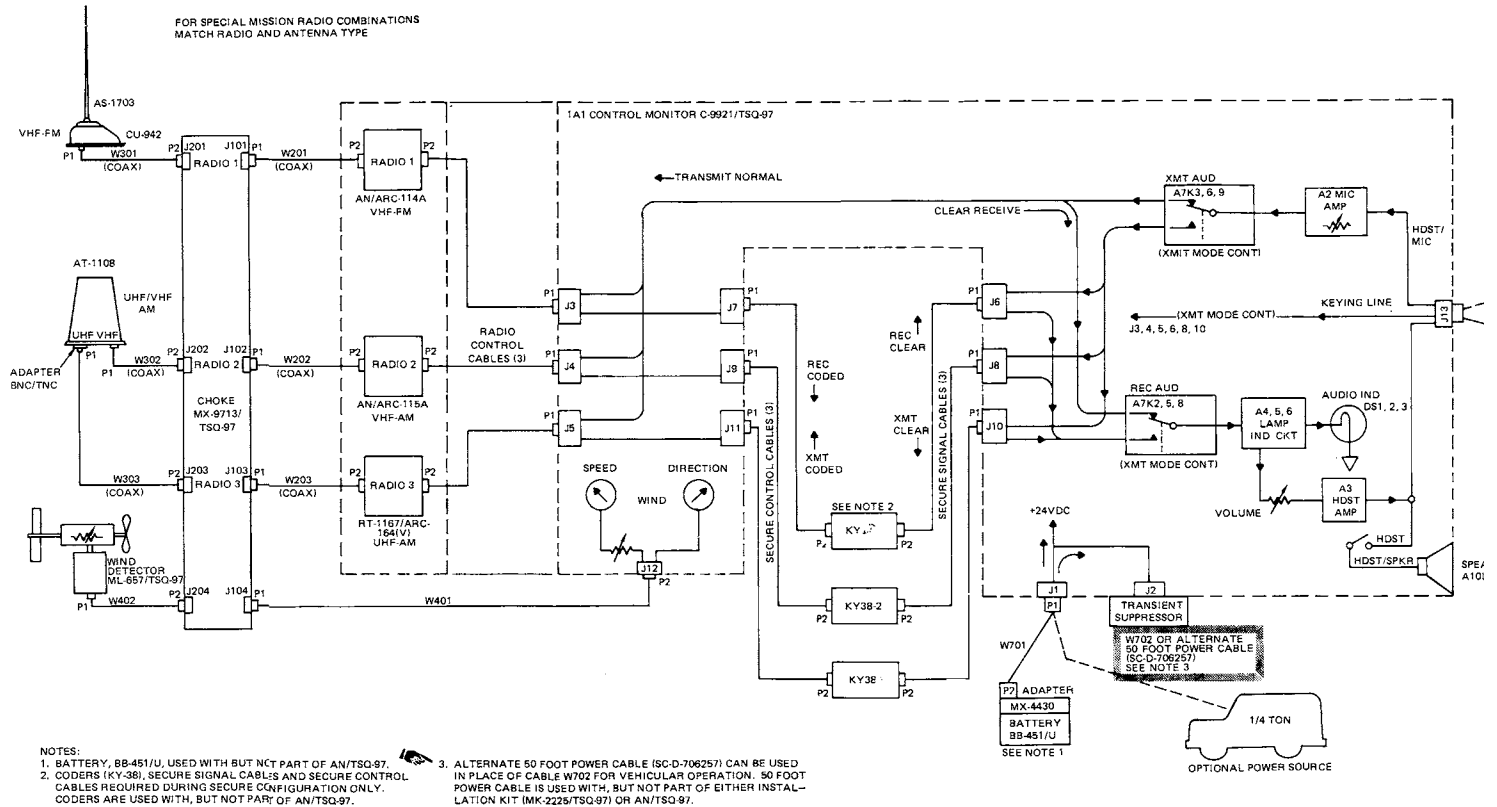


Figure FO-1. Operational Diagram, Air Traffic Control An/TSQ-97 with TSEC/KY-38 Security Equipment.

Change 2 FO-1



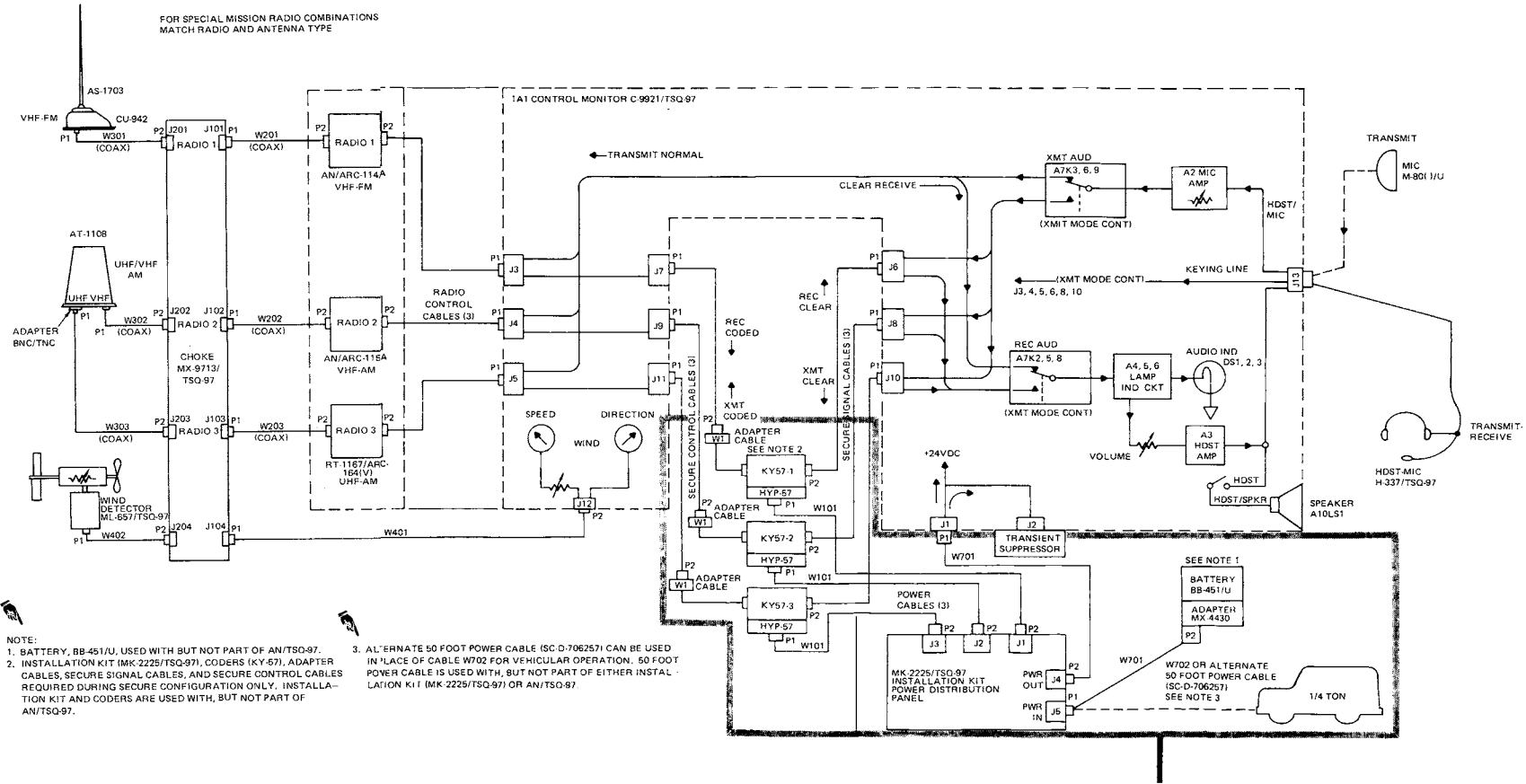


Figure FO-1A. Operational Diagram Air Traffic Control Facility AN/TSQ-97 with MK-2225/TSQ-97 Installation Kit and TSEC/KY-57 Security Equipment.

Change 2 FO-1A

**N O T E S:**

1. FOR FINAL ASSEMBLY SEE USAEC DWG SC-D-706000. FOR DATA LIST SEE DL-SC-B-706000. FOR OPERATIONAL DIAGRAM SEE USAEC DWG SC-D-706001
2. FOR SET-UP AND OPERATION OF THE AIR TRAFFIC CONTROL FACILITY, SEE TECHNICAL MANUAL TM-11-5895-800-12.
3. NORMAL MISSION CONFIGURATION SHOWN IN SOLID LINES. ANTENNAS, COUPLER AND ANTENNA ELEMENTS SHOWN IN DOTTED LINES MAY BE INCLUDED FOR SPECIAL MISSION CONFIGURATIONS, MATCHED WITH SPECIFIC RADIOS. FOR CABLE INTERFACE CONNECTIONS (NORMAL OR SPECIAL MISSION CONFIGURATION) REFER TO THE CABLING DIAGRAM ATTACHED TO THE INSIDE SURFACE OF THE CASE ASSEMBLY, REAR COVER.
4. CABLES ARE SHOWN LOOPED AROUND THE MAST AND BOOM TO PREVENT DAMAGE TO THE ELECTRICAL CONNECTIONS DURING WIND AND ICING CONDITIONS.
5. BATTERY, BB-451/4, IS USED WITH, BUT IS NOT PART OF, THE AIR TRAFFIC CONTROL FACILITY.
6. TOTAL WEIGHT EXCLUDING BATTERY IS 150 LBS.
7. CABLES NOT SHOWN:  
 3 EA DL-SC-B-706259 CABLE ASSY, SECURE SIGNAL  
 3 EA DL-SC-B-706262 CABLE ASSY, SECURE CONTROL  
 3 EA DL-SC-B-706265 CABLE ASSY, RADIO CONTROL

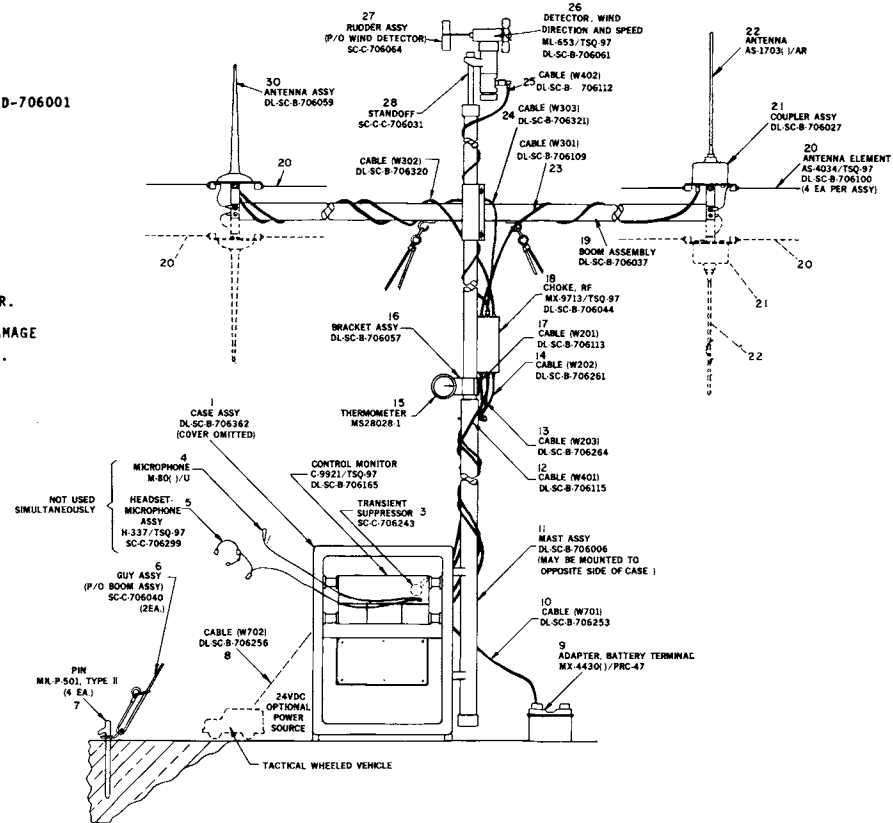


Figure FO-2. Air Traffic Control Facility ANTSQ-97, Installation Drawing

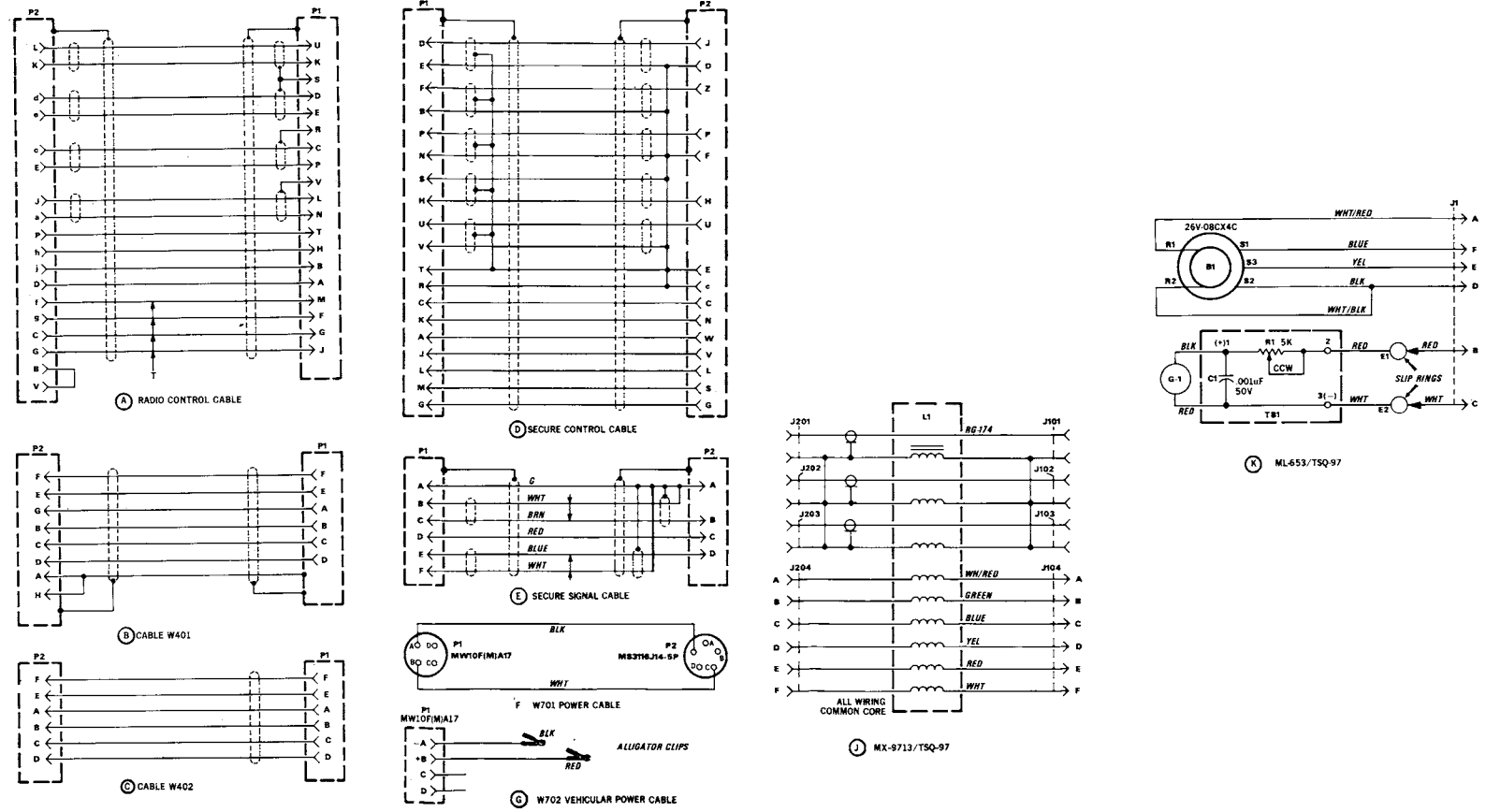


Figure FO-3. Electrical Schematic Diagrams, Cable Assemblies, Wind Detector ML-653/TSQ-97 and RF Choke MX-9713/TSQ-97

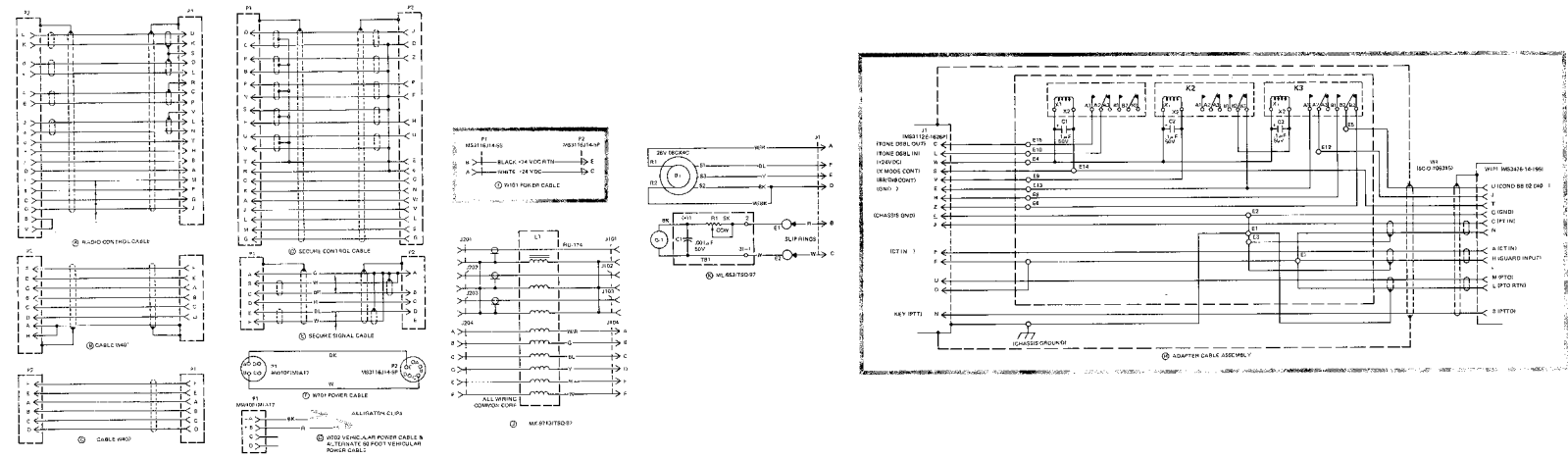


Figure Fo-3. Electrical Schematic Diagrams AN.TSQ-97 System Cables, MK-2225/TSQ-97 Installation Kit Cables, 50 Foot Power Cable, Radio-Frequency choke MX-9713/TSQ-97, Detector, Wind Direction and Speed ML-953/TSQ-97

Change 2 FO-9

**By Order of the Secretary of the Army:**

E.C. MEYER  
*General, United States Army*  
*Chief of Staff*

**Official:**

J. C. PENNINGTON  
*Major General, United States Army*  
*The Adjutant General*

**DISTRIBUTION:**

*Active Army:*

HISA (Ft Monmouth) (21)

USAINSCOM (2)

COE (1)

TSG (1)

USAARENBD (1)

DARCOM (1)

TRADOC (2)

Os Maj Comd (4)

TECOM (2)

USACC (4)

MDW (1)

Armies (2)

Corps (2)

Svc Colleges (1)

USASIGS (5)

USAADS (2)

USAFAS (2)

USAARMS (2)

USAIS (2)

USAES (2)

NG: State AG (3) Units - None

USAR: None

For explanation of abbreviations see, AR 310-50

USAICS (3)

MAAG (1)

USARMIS (1)

USAERDAA (1)

USAERDAW (1)

Ft Gordon (10)

Ft Carson (5)

Ft Gillem (3)

Ft Richardson (CERCOM Ofc) (2)

Army Dep (1) except

LBAD (14)

SAAD (30)

TOAD (14)

SHAD (3)

USA Dep (1)


Sig Sec USA Dep (1)

Units org under fol TOE: (2)

29-207

29-610

RECOMMENDED CHANGES TO EQUIPMENT TECHNICAL PUBLICATIONS

 <div style="border: 1px solid black; padding: 5px; width: fit-content; margin-left: auto; margin-right: auto;"> <p>THEN... JOT DOWN THE DOPE ABOUT IT ON THIS FORM, CAREFULLY TEAR IT OUT, FOLD IT AND DROP IT IN THE MAIL!</p> </div>		SOMETHING WRONG WITH THIS PUBLICATION?	
		FROM: (PRINT YOUR UNIT'S COMPLETE ADDRESS)	
PUBLICATION NUMBER TM 11-5825-270-10		PUBLICATION DATE 23 Jul 81	
PUBLICATION TITLE Radio Frequency R-2176/FRN			
BE EXACT... PIN-POINT WHERE IT IS		IN THIS SPACE TELL WHAT IS WRONG AND WHAT SHOULD BE DONE ABOUT IT:	
PAGE NO.	PARA-GRAPH		
PRINTED NAME, GRADE OR TITLE, AND TELEPHONE NUMBER		SIGN HERE:	

TEAR ALONG PERFORATED LINE

DA FORM 2028-2  
1 JUL 79

PREVIOUS EDITIONS ARE OBSOLETE.

P.S.—IF YOUR OUTFIT WANTS TO KNOW ABOUT YOUR RECOMMENDATION MAKE A CARBON COPY OF THIS AND GIVE IT TO YOUR HEADQUARTERS.

